

# ÄKTA pilot 600

## Operating Instructions

Original instructions



# Table of Contents

<b>1</b>	<b>Introduction .....</b>	<b>4</b>
1.1	About this manual .....	5
1.2	Important user information .....	6
1.3	Associated documentation .....	8
<b>2</b>	<b>Safety instructions .....</b>	<b>11</b>
2.1	Safety precautions .....	12
2.2	Labels .....	21
2.3	Emergency procedures .....	22
<b>3</b>	<b>System description .....</b>	<b>24</b>
3.1	Overview of the ÄKTA pilot 600 system .....	25
3.2	Description of the ÄKTA pilot 600 instrument .....	26
3.3	Tubing and connectors .....	33
3.4	Available modules for ÄKTA pilot 600 .....	36
3.5	In-line filters .....	40
3.6	Accessories .....	42
3.7	Description of the flow path .....	46
3.8	UNICORN system control software .....	48
3.8.1	<i>UNICORN software overview</i> .....	49
3.8.2	<i>The System Control module</i> .....	50
<b>4</b>	<b>Installation .....</b>	<b>55</b>
4.1	Site preparation .....	56
4.1.1	<i>Delivery, storage and unpacking</i> .....	57
4.1.2	<i>Room requirements</i> .....	59
4.1.3	<i>Site environment</i> .....	62
4.1.4	<i>Power requirements</i> .....	64
4.1.5	<i>Computer requirements</i> .....	66
4.2	Installing the ÄKTA pilot 600 system .....	67
4.2.1	<i>Introduction</i> .....	69
4.2.2	<i>Install the instrument and computer</i> .....	70
4.2.3	<i>Fit inlet and outlet tubing</i> .....	72
4.2.4	<i>Install the Air Trap</i> .....	79
4.2.5	<i>Install the pump rinsing system</i> .....	82
4.2.6	<i>Fit the pH electrode</i> .....	84
4.2.7	<i>Install optional external air sensors</i> .....	88
4.2.8	<i>Install the optional steel filter housing</i> .....	90
4.2.9	<i>Install the optional ULTA filter</i> .....	94
4.2.10	<i>Install and uninstall optional modules</i> .....	99
4.3	Connecting the system units .....	106
4.4	Installing UNICORN software .....	108
4.5	Connecting the ÄKTA pilot 600 instrument to UNICORN software .....	109
4.6	Performance tests .....	114
4.7	Delay volumes .....	115
4.8	Moving the ÄKTA pilot 600 system .....	117
<b>5</b>	<b>Prepare the system for a run .....</b>	<b>120</b>
5.1	Start the instrument and software .....	121

5.2	Prepare the flow path .....	122
5.3	Prepare the pH monitor (optional) .....	124
5.4	Prime the flow path .....	130
5.5	Fill the air trap and the filter (optional) .....	134
5.6	Connect the columns .....	139
<b>6</b>	<b>Perform a run .....</b>	<b>143</b>
6.1	Before you start .....	144
6.2	Manual operations .....	146
6.3	Sample application .....	147
6.4	Start a method run .....	150
6.5	Monitor the run .....	151
6.6	Procedures after the run .....	152
<b>7</b>	<b>Maintenance .....</b>	<b>154</b>
7.1	Maintenance schedule .....	156
7.2	Cleaning procedures .....	158
7.2.1	<i>Cleaning before planned service</i> .....	159
7.2.2	<i>Clean the instrument surfaces</i> .....	160
7.2.3	<i>Clean the flow path</i> .....	161
7.2.4	<i>Clean and store the pH electrode</i> .....	163
7.3	Replacement procedures .....	165
7.3.1	<i>Change the pump rinsing solution</i> .....	166
7.3.2	<i>Replace pump rinse tubing</i> .....	168
7.3.3	<i>Replace flow path tubing and connectors</i> .....	170
7.3.4	<i>Replace valve membranes</i> .....	171
7.3.5	<i>Replace the main fuses</i> .....	177
<b>8</b>	<b>Troubleshooting .....</b>	<b>179</b>
<b>9</b>	<b>Reference information .....</b>	<b>182</b>
9.1	System specifications .....	183
9.2	Tubing and connectors .....	184
9.3	Chemical resistance guide .....	185
9.3.1	<i>General information</i> .....	186
9.3.2	<i>Chemical resistance specifications</i> .....	187
9.4	Recycling information .....	189
9.5	Regulatory information .....	190
9.5.1	<i>Contact information</i> .....	191
9.5.2	<i>European Union and European Economic Area</i> .....	192
9.5.3	<i>Eurasian Economic Union</i> <i>Евразийский экономический союз</i> .....	193
9.5.4	<i>Regulations for North America</i> .....	195
9.5.5	<i>Regulatory statements</i> .....	196
9.5.6	<i>Declaration of Hazardous Substances (DoHS)</i> .....	197
9.5.7	<i>Other regulations and standards</i> .....	199
9.6	Health and Safety Declaration Form .....	200
	<b>Index .....</b>	<b>202</b>

# 1 Introduction

## About this chapter

This chapter contains important user information, descriptions of safety notices, intended use of the ÄKTA™ pilot 600 system, and lists of associated documentation.

## In this chapter

Section		See page
1.1	About this manual	5
1.2	Important user information	6
1.3	Associated documentation	8

## 1.1 About this manual

### Purpose of this manual

The Operating Instruction manual provides information needed to install, operate and maintain the product in a safe way.

### Scope of this manual

The *Operating Instructions* cover the ÄKTA pilot 600 instrument, optional modules and accessories. The ÄKTA pilot 600 instrument is controlled by a PC running UNICORN system control software version 7.3 or higher. For detailed information about the system control software, see the UNICORN user documentation. For information about chromatography columns, see the respective user manuals or instructions.



### Typographical conventions

Software items are identified in the text by ***bold italic*** text.

Hardware items are identified in the text by **bold** text.

In electronic format, references in *italics* are clickable hyperlinks.

## 1.2 Important user information

### Read this before operating the product



**All users must read the entire *Operating Instructions* before installing, operating or maintaining the product.**

Always keep the *Operating Instructions* at hand when operating the product.

Do not install, operate, or perform maintenance on the product in any other way than described in the user documentation. If you do, you may be exposed or expose others to hazards that can lead to personal injury and you may cause damage to the equipment.

### Intended use of the product

The ÄKTA pilot 600 system is a low-pressure automated liquid chromatography system intended for the precision transportation of fluids to and from chromatography columns of varying sizes.

The system is intended for process development, scale up and scale down of processes, as well as sanitary production of material for pre-clinical and clinical phases of applicable scale.

Process engineers, process operators and other trained laboratory personnel are the intended users of the ÄKTA pilot 600 system.

The ÄKTA pilot 600 system shall not be used in any clinical procedures, or for diagnostic purposes.

The ÄKTA pilot 600 system shall not be used in a potentially explosive atmosphere or for handling flammable liquids.

### Prerequisites

In order to follow this manual and use the system in the manner it is intended:

- The user should have a general understanding of how the computer and Microsoft® Windows® work.
- The user must understand the concepts of liquid chromatography.
- The user must have read and understood the Safety instructions chapter in this manual.
- The ÄKTA pilot 600 system must have been installed according to the instructions in [Chapter 4 Installation, on page 55](#).
- A user account must have been created according to the *UNICORN™ Administration and Technical Manual*.

## Definitions

This user documentation contains safety notices (WARNING, CAUTION, and NOTICE) concerning the safe use of the product. See definitions below.



### **WARNING**

**WARNING** indicates a hazardous situation which, if not avoided, could result in death or serious injury. It is important not to proceed until all stated conditions are met and clearly understood.



### **CAUTION**

**CAUTION** indicates a hazardous situation which, if not avoided, could result in minor or moderate injury. It is important not to proceed until all stated conditions are met and clearly understood.



### **NOTICE**

**NOTICE** indicates instructions that must be followed to avoid damage to the product or other equipment.

## Notes and tips

**Note:** *A note is used to indicate information that is important for trouble-free and optimal use of the product.*

**Tip:** *A tip contains useful information that can improve or optimize your procedures.*

## 1.3 Associated documentation

### Introduction

This section describes the user documentation that is delivered with the product, and how to find related literature that can be downloaded or ordered from Cytiva.

### User documentation for ÄKTA pilot 600

The user documentation listed in the table below. Translations of the *Operating Instructions* are provided on the User Documentation CD, together with the *User Manual*, *Product Documentation*, and *Unpacking Instructions*. Printed copies of the *User Manual* are available on request from Cytiva.

Documentation	Main contents
<i>ÄKTA pilot 600 Operating Instructions</i> (this document)	<p>Instructions needed to prepare and operate the ÄKTA pilot 600 system in a correct and safe way.</p> <p>System overview, site requirements, and instructions for moving the system within the same building.</p> <p>Instructions for basic maintenance and troubleshooting.</p>
<i>ÄKTA pilot 600 User Manual</i>	<p>Additional information in order to get the optimal performance from the system.</p> <p>Functional description of modules.</p> <p>Instructions for maintenance and troubleshooting activities.</p>
<i>ÄKTA pilot 600 Site Preparation Guide</i>	<p>Information needed to prepare the site for installation and use of the ÄKTA pilot 600 system.</p>
<i>ÄKTA pilot 600 Unpacking Instructions</i>	<p>Instructions for handling the delivery package and unpacking the ÄKTA pilot 600 system.</p>
<i>ÄKTA pilot 600S Product Documentation</i>	<p>Specifications and material conformity.</p>



## Product Documentation binders (Regulatory version only)

In addition to the user documentation, the documentation package supplied with ÄKTA pilot 600R (Regulatory) systems also includes Product Documentation binders containing detailed specifications and traceability documents, specific to each individual system.

For more information about the ÄKTA pilot 600R instrument, see [Standard and Regulatory versions of the instrument, on page 26](#).

The following table provides some examples of documents that can be found in the Product Documentation package delivered with ÄKTA pilot 600R.

Document	Abbreviation	Purpose/Contents
Piping and Instrumentation Diagram	P&ID	Schematic overview of the process flow, components and instruments and the control system.
General Specification	GS	Technical data for the system.
Assembly Drawing	AD	Physical layout. Provides dimensional data.
Bill of Material	BOM	Description of process-related components, including wetted materials and specifications.
Declaration of Conformity	DoC	Declaration of Conformity for EU and/or other regions.
Spare Part List	SPL	List of spare parts available from Cytiva.

## UNICORN documentation

The UNICORN documentation is listed in the following table. The documents are available in the **UNICORN Online Help and Documentation** section of the online help (see [Online help, on page 10](#)).

Documentation	Main contents
Getting started with Evaluation (accessed through the online help in the UNICORN Evaluation module)	<ul style="list-style-type: none"> <li>• Video clips showing common workflows in the Evaluation module.</li> <li>• Overview of features of the Evaluation module.</li> </ul>
UNICORN Method Manual <sup>1</sup>	<ul style="list-style-type: none"> <li>• Overview and detailed descriptions of the method creation features in UNICORN.</li> <li>• Workflow descriptions for common operations.</li> </ul>

## 1 Introduction

### 1.3 Associated documentation

Documentation	Main contents
UNICORN Administration and Technical Manual <sup>1</sup>	<ul style="list-style-type: none"><li>• Overview and detailed description of network setup and complete software installation.</li><li>• Administration of UNICORN and the UNICORN database.</li></ul>
UNICORN Evaluation Manual <sup>1</sup>	<ul style="list-style-type: none"><li>• Overview and detailed descriptions of the Evaluation Classic module in UNICORN.</li><li>• Description of the evaluation algorithms used in UNICORN.</li></ul>
UNICORN System Control Manual <sup>1</sup>	<ul style="list-style-type: none"><li>• Overview and detailed description of the system control features in UNICORN.</li><li>• Includes general operation, system settings and instructions on how to perform a run.</li></ul>
UNICORN OPC User Manual	Instructions for setting up and using the UNICORN OPC server.

<sup>1</sup> Current UNICORN version is added to the title of the manual.

## Online help

To access online help in any module in UNICORN software, use the **Help** menu or press the **F1** key on the keyboard. Help is displayed for the currently active pane or dialog box.

## User documentation and other literature on the web

User documentation and other literature related to ÄKTA pilot 600 system may be downloaded from the web. Follow the steps below to access the documentation.

Step	Action
------	--------

- |   |  |
|---|--|
| 1 | Go to <a href="http://cytiva.com/aktapilot">cytiva.com/aktapilot</a> . |
| 2 | Navigate to <b>RELATED DOCUMENTS</b> .                                 |
| 3 | Select the type of document and download the chosen literature.        |

## 2 Safety instructions

### About this chapter

This chapter describes safety precautions, labels and symbols that are attached to the equipment. In addition, the chapter describes emergency and recovery procedures.

### Important



#### **WARNING**

**Before installing, operating or maintaining the product, all users must read and understand the entire contents of this chapter to become aware of the hazards involved.**

### In this chapter

<b>Section</b>	<b>See page</b>
2.1 Safety precautions	12
2.2 Labels	21
2.3 Emergency procedures	22

## 2.1 Safety precautions

### Introduction

ÄKTA pilot 600 is powered by mains voltage and handles materials that can be considered hazardous. Before installing, operating or maintaining the system, you must be aware of the hazards described in this manual.

**Follow the instructions provided to avoid injury to the operator or other personnel, damage to samples or other substances handled by the equipment, to the product, or to other equipment in the area.**

The safety precautions in this section are grouped in the following categories:

- General precautions
- Personal protection
- Flammable liquids and explosive environment
- Installing and moving the product
- Power supply
- Operation
- Maintenance
- Decommissioning

### General precautions



#### **WARNING**

Do not operate the product in any other way than described in the ÄKTA pilot 600 user documentation.



#### **WARNING**

Only properly trained personnel may operate and maintain the product.



#### **WARNING**

**Accessories.** Use only accessories supplied or recommended by Cytiva.

**WARNING**

Do not use the product if it is not working properly, or if it has suffered any damage, for example:

- damage to the power cord or its plug
- damage caused by dropping the equipment
- damage caused by splashing liquid onto it

## Personal protection

**WARNING**

Always use appropriate Personal Protective Equipment (PPE) during operation and maintenance of this product.

**WARNING**

**Hazardous substances and biological agents.** When using hazardous chemical and biological agents, take all suitable protective measures, such as wearing protective clothing, glasses and gloves resistant to the substances used. Follow local and/or national regulations for safe operation and maintenance of this product.

**WARNING**

**Spread of biological agents.** The operator must take all necessary actions to avoid spreading hazardous biological agents. The facility must comply with the national code of practice for biosafety.

**WARNING**

**High pressure.** The product operates under high pressure. Wear protective glasses and other required Personal Protective Equipment (PPE) at all times.

## Flammable liquids and explosive environment



### WARNING

**Flammable liquids.** This product is **not approved** for handling flammable liquids.



### WARNING

**Explosive environment.** The product is **not approved** for work in a potentially explosive atmosphere. The product does not fulfill the requirements of the ATEX Directive.

## Installing and moving the product



### WARNING

**Heavy object.** Use suitable lifting equipment when moving the instrument. Four people are required to lift the system safely. All lifting and moving must be performed in accordance with local regulations.



### WARNING

**Access to power plug.** Do not block access to the power outlet and power plug. The power cord with plug must always be easy to disconnect.



### WARNING

When moving the instrument for maintenance or other purposes, disconnect all cables from wall sockets and separate equipment so that the cables do not pull on the instrument or equipment.



### WARNING

Remove any column with associated tubing, bottles, and inlet, outlet and waste tubing before moving the instrument.

**CAUTION**

**Tipping risk.** Before moving the instrument on a trolley, secure the instrument using straps with a minimum strength of 100 kg.

**CAUTION**

**pH electrode.** Handle the pH electrode with care. The glass tip may break and cause injury.

**CAUTION**

The product is filled with 20% ethanol at delivery. **The alcohol can be hazardous to humans if consumed.** Flush out the alcohol before assembling, testing or integrating the product into the intended process context.

**CAUTION**

**Installing the computer.** The computer must be installed and used according to the instructions provided by the manufacturer of the computer.

**CAUTION**

When installing additional modules, make sure that the modules are correctly mounted and sealed against the front of the instrument. Incorrect mounting can cause leakage of liquid in to the instrument electronics.

**CAUTION**

If the product is installed on a trolley, keep the trolley wheels locked at all times except when moving the product.

## Power supply

**WARNING**

**Power cord.** Only use power cords with approved plugs delivered or approved by Cytiva.

## 2 Safety instructions

### 2.1 Safety precautions



#### **WARNING**

**Protective ground.** The product must always be connected to a grounded power outlet.



#### **WARNING**

For continued protection from fire hazard, replace only with same type and rating of fuse.

## Operation



#### **WARNING**

Before use, check that the column is not damaged or otherwise defective. Damaged or defective columns might leak or rupture.



#### **WARNING**

Before connecting a column, read the instructions for use of the column.



#### **WARNING**

**High pressure.** The flow rate may under no circumstances exceed the specified column maximum flow rate. High flows might affect the packed resin, causing the pressure to exceed the specified column maximum pressure.



#### **WARNING**

To avoid exposing system components to excessive pressure, make sure that the system pressure limit is set at or below the specified maximum pressure for the component with the lowest pressure limit (including in-line filters, which often have lower pressure tolerance than other system components).



#### **WARNING**

When ULTA filters are used, the system pressure alarm must be set to a maximum of 5 bar in the UNICORN software **System Settings**.





**WARNING**

**Overpressure.** Never block the outlet tubing with, for instance, stop plugs, since this will create overpressure and might result in injury.



**CAUTION**

The flow path may remain pressurized while a run is paused. Do not loosen any connections.



**CAUTION**

Do not place items such as buffer bottles on top of the instrument.



**CAUTION**

**Avoid spillage and overflow.** Make sure that the waste tubing is inserted in an appropriate waste container and secured in place.



**CAUTION**

Make sure that the waste container is dimensioned for maximum possible volume when the equipment is left unattended.



**CAUTION**

Secure all outlet tubing carefully so that it remains in the container even when high flow rates cause vibrations in the tubing.



**CAUTION**

Do not use a Superloop without its protective jacket. The Superloop may crack if exposed to overpressure.

## Maintenance



### WARNING

**Electrical shock hazard.** All repairs should be done by service personnel authorized by Cytiva. Do not open any covers or replace parts unless specifically stated in the user documentation.



### WARNING

**Disconnect power.** Always disconnect power from the instrument before replacing any component on the instrument, unless stated otherwise in the user documentation.



### WARNING

**Use only approved parts.** Only spare parts and accessories that are approved or supplied by Cytiva may be used for maintaining or servicing the product.



### WARNING

For continued protection against injury risks due to fluid jets, burst tubes or potentially explosive atmosphere, the user must test the tubing system for leakage at maximum operating pressure.

Always perform a leakage test using distilled water after assembly or maintenance.



### WARNING

**Hazardous chemicals during run.** When using hazardous chemicals, flush the entire system tubing with distilled water, before service and maintenance.



### WARNING

**Hazardous chemicals.** Always empty the system of liquids before service.

**WARNING**

**Decontaminate before maintenance.** To avoid exposing personnel to potentially hazardous substances, clean and sanitize the ÄKTA pilot 600 system before maintenance or service.

**WARNING**

**Corrosive substance.** NaOH is corrosive and therefore dangerous to health. When using hazardous chemicals, avoid spillage and wear protective glasses and other suitable Personal Protective Equipment (PPE).

**WARNING**

If a fuse requires repeated replacement, do not continue to use the instrument. Contact an authorized service engineer.

**WARNING**

**Avoid leakage.** When replacing the filter cassette, make sure that the cassette is correctly fitted.

**CAUTION**

**Sharp tool.** The tubing cutter is very sharp and can cause injuries if it is not handled with care.

**CAUTION**

The system uses high intensity ultra-violet light that is harmful to the eyes. Before changing or cleaning the UV detector, make sure that the UV lamp is switched off or that the power is disconnected.

## Decommissioning

**WARNING**

**Decommissioning.** Decontaminate the equipment before decommissioning to make sure that hazardous residues are removed.

## 2 Safety instructions

### 2.1 Safety precautions



#### **CAUTION**

Always use appropriate personal protective equipment when decommissioning the equipment.

## 2.2 Labels

### Introduction

This section describes the system label and other safety or regulatory labels that are attached to the product.

### System label

The system label is located on the back of the equipment. The system label identifies the equipment and shows electrical data, regulatory compliance, and warning symbols.

### Description of symbols on the instrument label

The following symbols may be present on the instrument labels.

Label	Meaning
	<b>Warning!</b> Read the user documentation before using the system. Do not open any covers or replace parts unless specifically stated in the user documentation.
<b>Voltage</b> <b>Frequency</b> <b>Max. Power</b>	Electrical requirements: <ul style="list-style-type: none"> <li>• Voltage (VAC ~)</li> <li>• Frequency (Hz)</li> <li>• Max. power (VA)</li> </ul>
<b>Protection Class</b>	Degree of protection provided by the enclosure.
<b>Mfg. Year</b>	Year (YYYY) and month (MM) of manufacture

## 2.3 Emergency procedures

### Introduction

This section describes how to shut down the ÄKTA pilot 600 system in an emergency situation, and the procedure for restarting the instrument.

The section also describes the result in the event of power failure.

### Precautions



#### **WARNING**

**Access to power plug.** Do not block access to the power outlet and power plug. The power cord with plug must always be easy to disconnect.

### Emergency shutdown

To shut down the system in an emergency, disconnect the instrument power cord from the power source. Any ongoing activity will be terminated immediately. Run data up to the time of the interruption will be saved.

**Note:** *If the instrument is connected to an UPS (Uninterruptible Power Supply), disconnect the instrument from the UPS.*



#### **NOTICE**

Do not leave the instrument in an emergency stop condition. Flush the flow path with water or buffer when the emergency has been dealt with.

### Power failure

If power to both the computer and the ÄKTA pilot 600 instrument is lost, the run is interrupted immediately. Data collected up to the time of the power failure is saved in the UNICORN software.

The consequences of partial power failure (for example, if power to the computer is lost but that to the ÄKTA pilot 600 instrument is maintained) are described in the ÄKTA pilot 600 User Manual.

**Note:** *Connecting the instrument and computer to an uninterruptible power supply (UPS) can help to prevent loss of data and material during a power failure.*

## **Restart after emergency shutdown or power loss**

When power is restored after a power failure or emergency shutdown, perform the actions below as required:

- Restart the instrument if necessary.
- Restart the computer and UNICORN software.
- Re-establish connection between UNICORN and the instrument.
- If the run has been aborted, recover or discard remaining sample and clean the flow path as appropriate.

# 3 System description

## About this chapter

This chapter gives an overview of the ÄKTA pilot 600 instrument and accessories, and the UNICORN system control software.

## In this chapter

<b>Section</b>	<b>See page</b>
3.1 Overview of the ÄKTA pilot 600 system	25
3.2 Description of the ÄKTA pilot 600 instrument	26
3.3 Tubing and connectors	33
3.4 Available modules for ÄKTA pilot 600	36
3.5 In-line filters	40
3.6 Accessories	42
3.7 Description of the flow path	46
3.8 UNICORN system control software	48



## 3.1 Overview of the ÄKTA pilot 600 system

### Introduction

The ÄKTA pilot 600 system includes the ÄKTA pilot 600 instrument, the UNICORN control software, user documentation, and optional modules and accessories.

The ÄKTA pilot 600 instrument is available in a Standard and a Regulatory version (see [Standard and Regulatory versions of the instrument, on page 26](#)).

### Illustration of the ÄKTA pilot 600 system

The illustration below shows an ÄKTA pilot 600 instrument with UNICORN control software running on a PC.



### Optional modules and accessories

Optional modules can be added in unused positions in the instrument chassis, or placed in an extension box beside the instrument. For more information, see [Section 3.4 Available modules for ÄKTA pilot 600, on page 36](#).

**Note:** *Adding optional modules to the ÄKTA pilot 600R system will invalidate the documentation provided with the system. Contact Cytiva if you want to modify an ÄKTA pilot 600R system.*

A number of accessories are available, for example an extension stand for columns. For more information, see [Section 3.6 Accessories, on page 42](#).

## 3.2 Description of the ÄKTA pilot 600 instrument

### Introduction

The ÄKTA pilot 600 instrument uses a modular design, with all the liquid handling modules placed on the front of the instrument. All parts of the flow path are sanitizable.

This section describes the main parts of the instrument.

### Standard and Regulatory versions of the instrument

The ÄKTA pilot 600 instrument is available in two versions:

- ÄKTA pilot 600S, Standard instrument, with the possibility to install optional modules.
- ÄKTA pilot 600R, Regulatory instrument. The ÄKTA pilot 600R system is supplied fully configured according to the purchase specifications, and is tested at the factory. ÄKTA pilot 600R is delivered with the additional instrument specific, detailed Product Documentation. Installing, removing or moving modules will make the Product Documentation invalid.

The instrument version is indicated on the front panel as shown in the illustration below:

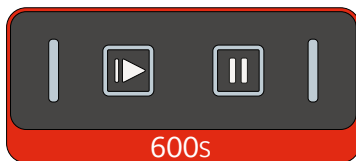

Standard instrument

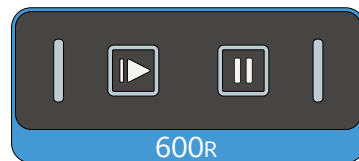

Regulatory instrument

### Operating ranges

The following table shows the main operational limits of the ÄKTA pilot 600 instrument.

Parameter	Range
Flow rate	0.1 to 600 mL/min
Gradient flow rate 0 to 100% B	4 to 600 mL/min
Dual pump flow rate	600 to 1200 mL/min
Max. operating pressure	2 MPa (20 bar)
UV monitor wavelength	190 to 700 nm

## ÄKTA pilot 600 instrument front panel

The following illustration shows an example of the ÄKTA pilot 600 instrument, with all types of modules installed. The location of modules can vary, depending on customer requirements. Optional modules are indicated in the table.

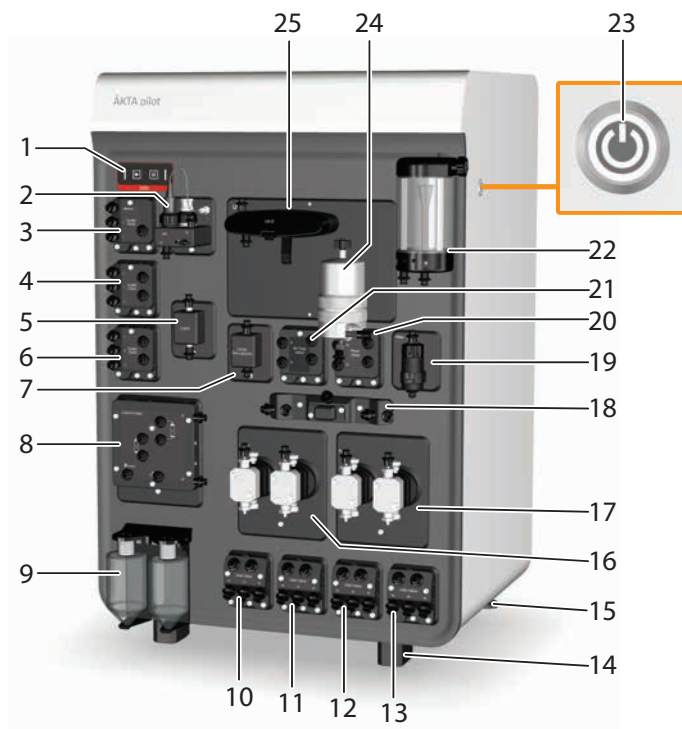

Part	Description	Label	Optional (*)
1	Control panel. The instrument version is indicated below the control panel: <b>600S</b> (red) or <b>600R</b> (blue)	-	
2	pH monitor	<b>pH</b>	*
3	Outlet valve 1-3, port 1 can be used for waste	<b>Outlet Valve W/1 2 3</b>	
4	Outlet valve 4-6	<b>Outlet Valve 4 5 6</b>	*
5	Conductivity monitor	<b>Cond</b>	

### 3 System description

#### 3.2 Description of the ÄKTA pilot 600 instrument

<b>Part</b>	<b>Description</b>	<b>Label</b>	<b>Optional (*)</b>
6	Outlet valve 7-9	<b>Outlet Valve 7 8 9</b>	*
7	Pre-column Conductivity monitor	<b>Cond Pre- column</b>	*
8	Column valve, including pre- and post-column pressure sensor	<b>Column Valve</b>	
9	Bottles for pump rinsing solution	-	
10	Inlet valve A1-A3	<b>Inlet Valve A1 A2 A3</b>	
11	Inlet valve A4-A6	<b>Inlet Valve A4 A5 A6</b>	*
12	Inlet valve B1-B3	<b>Inlet Valve B1 B2 B3</b>	
13	Inlet valve B4-B6	<b>Inlet Valve B4 B5 B6</b>	*
14	Fixed plastic feet	-	
15	Adjustable feet	-	
16	System pump A	<b>Pump A</b>	
17	System pump B	<b>Pump B</b>	
18	Flow restrictor, including system pressure sensor	-	
19	Mixer module	<b>Mixer</b>	*
20	Mixer valve	<b>Mixer Valve</b>	*
21	Air trap valve, including air sensor	<b>Air Trap Valve</b>	
22	Air trap	-	
23	<b>ON/OFF</b> button	-	
24	In-line filter (stainless steel filter housing shown)	-	*
25	UV monitor	<b>UV</b>	

## Description of the ON/OFF button

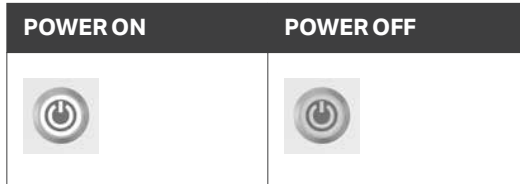

- To switch on the instrument, press the **ON/OFF** button. The button lights up to indicate the POWER ON state.
- To shut down the system: first shut down the computer, then press the **ON/OFF** button on the instrument. The button illumination flashes until the instrument is switched off.

**Note:** To completely remove mains voltage from the instrument, unplug the power cord.

## Connectors on the rear panel

The following illustration shows the connector panel, which is located on the back of the instrument.

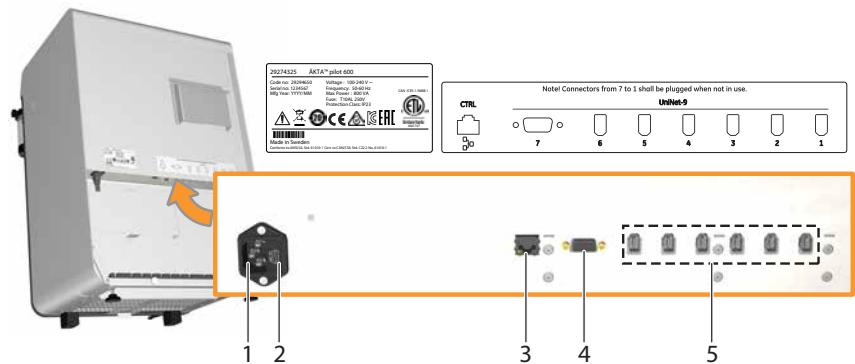

Part	Function
1	<b>Mains In</b> power input connector
2	Fuse holder
3	<b>Computer</b> connector, for connecting to the computer running UNICORN control software
4	<b>UniNet-9</b> connector (D-sub type)

### 3 System description

#### 3.2 Description of the ÄKTA pilot 600 instrument

Part	Function
5	<b>UniNet-9</b> connectors, for connecting additional modules to the instrument. Termination plugs (jumpers) must be plugged into <b>UniNet-9</b> connectors that are not used. Spare termination plugs can be stored in the holder on the back of the instrument: 

### Illustration of the control panel

The instrument control panel shows the current status of the instrument and allows the user to pause and continue a run.

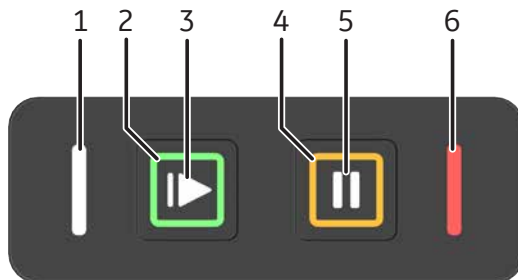





Part	Function
1	<b>Power/Communication</b> indicator (white)
2	<b>Continue</b> indicator* (green)
3	<b>Continue</b> button (white)
4	<b>Pause</b> indicator* (orange)
5	<b>Pause</b> button (white)
6	<b>Alarm and Error</b> indicator (red)

\*The **Continue** and **Pause** indicators will change state, both when the buttons are pressed on the control panel, and when the corresponding buttons are pressed in **UNICORN System Control**.



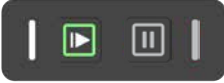
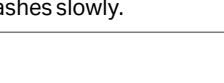

## Status indications on the control panel

The following table describes the different states that can be shown. The state is also shown in UNICORN.

Display	State	Description
	<b>Off</b>	The instrument is turned off.
The <b>Power/Communication</b> indicator flashes slowly. 	<b>Power on</b>	Power is on, but the instrument has no communication with the instrument server.
The <b>Power/Communication</b> indicator flashes quickly. 	<b>Connecting</b>	The system is starting up.
The <b>Power/Communication</b> indicator shows a steady light. 	<b>Ready</b>	The instrument is ready to use.
Both the <b>Power/Communication</b> indicator and <b>Continue</b> button show a steady light. 	<b>Run</b>	A run is ongoing.
The <b>Power/Communication</b> indicator shows a constant light and the <b>Continue</b> button flashes slowly. 	<b>Wash</b>	A wash instruction or a pump synchronization is ongoing.

### 3 System description

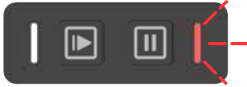
#### 3.2 Description of the ÄKTA pilot 600 instrument

Display	State	Description
	<b>Hold</b>	A run has been put on hold.
<p>Both the <b>Power/Communication</b> indicator and <b>Pause</b> button show a steady light.</p> 	<b>Pause</b>	<p>A run has been paused by the user.</p> <p> <b>CAUTION</b></p> <p>The flow path may remain pressurized while a run is paused. Do not loosen any connections.</p>
<p><b>Power/Communication</b> indicator: constant light.</p> <p><b>Alarm and error</b> indicator: flashing light.</p> 	<b>Alarms and errors</b>	<p>The system has been paused due to an alarm or error.</p> <p>To resume the run:</p> <ul style="list-style-type: none"> <li>• acknowledge the alarm</li> <li>• correct the cause of the alarm</li> <li>• continue the run in UNICORN</li> </ul>
<p>The <b>Power/Communication</b> indicator shows a pulsating light.</p> 	<b>Power-save</b>	The system is in power-saving mode.
<p>All indicators are lit in a moving pattern, one indicator at a time.</p> 	<b>Re-programming</b>	A module is being re-programmed to be compatible with the current instrument configuration.



## 3.3 Tubing and connectors

### Introduction

The section describes the tubing components used on the ÄKTA pilot 600 instrument.

### Tubing dimensions

The following table shows the dimensions used for the tubing between flow path components:

Location	Dimension
To inlets and between inlet valves and pumps	Inner diameter (i.d.) 4.8 mm (3/16 in) Outer diameter (o.d.) 6.4 mm (1/4 in)
After the pumps	i.d. 3.2 mm (1/8 in) o.d. 4.8 mm (3/16 in)



#### NOTICE

Only use tubing intended for use with ÄKTA pilot 600 and provided by Cytiva. Using other types of tubing might cause leakage or damage to the instrument.

### SNAP connectors

SNAP connectors are used to form a tight connection to the ports of the flow path components. There are two sizes of SNAP connectors, for 3.2 mm and 4.8 mm i.d. tubing respectively.

The illustration shows the connector parts and the nipple of a valve port, where the SNAP connector is attached.

3 System description  
3.3 Tubing and connectors

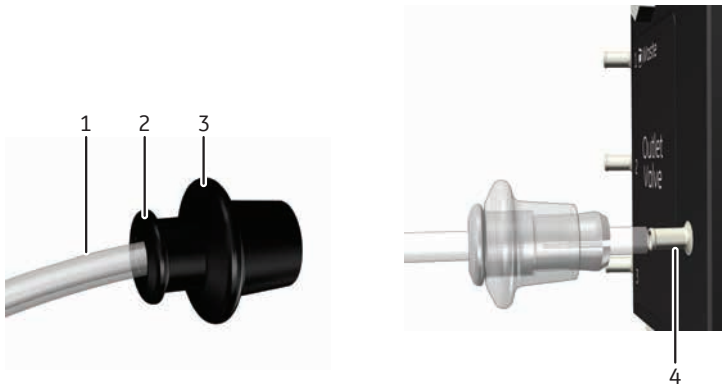

Part	Function
1	Tubing
2	Connector
3	Sleeve
4	Nipple

### Tubing cutter

A tubing cutter is included with the instrument. The illustration below shows the tubing cutter in use.



## Tube bender

The illustration below shows the tube bender that is included with the instrument.



## 3.4 Available modules for ÄKTA pilot 600

### Introduction

The ÄKTA pilot 600 Standard instrument is always delivered with the standard modules installed. The Standard instrument may be expanded by adding optional modules to the flow path. Optional modules are delivered in separate packages.

Optional modules can be installed in unused positions in the chassis, or in an Extension box.

### Available modules

The following table lists the modules that are available for the ÄKTA pilot 600 instrument. Optional modules are indicated with an asterisk (\*).

**Note:** *Inlet valves and outlet valves have specific product codes depending on the port numbers.*

*Each valve has a unique ID in the system and can only be used in a specific position in the flow path.*

Module	Description	Optional
Inlet valve A 1-3	Inlet valve for System pump A with inlet ports <b>A1</b> to <b>A3</b> . The inlet valves can be used to select buffer, sample and cleaning solutions.	
Inlet valve A 4-6	Inlet valve for System pump A, for ports <b>A4</b> to <b>A6</b> <b>Note:</b> <i>Inlet valve A 1-3 must be installed.</i>	*
Inlet valve A 7-9	Inlet valve for System pump A, for ports <b>A7</b> to <b>A9</b> . <b>Note:</b> <i>Inlet valves A 1-3 and 4-6 must be installed.</i>	*
Inlet valve B 1-3	Inlet valve for System pump B, for ports <b>B1</b> to <b>B3</b>	
Inlet valve B 4-6	Inlet valve for System pump B, for ports <b>B4</b> to <b>B6</b> <b>Note:</b> <i>Inlet valve B 1-3 must be installed.</i>	*
External air sensors	Up to four external air sensors can be installed in the inlet tubing. for more information, see <a href="#">External air sensors, on page 38</a> .	*
System pump A	A high precision piston pump, which delivers buffer or sample	
System pump B	A high precision piston pump, which which delivers buffer or sample and can be used for gradient elution	

Module	Description	Optional
Mixer	Mixes the buffers delivered from the system pumps, in a 5 mL mixer chamber, to a homogeneous buffer composition.	*
Mixer valve	A valve that directs the flow through the mixer, or bypasses the mixer, for example during sample application.  <b>Note:</b> <i>The Mixer valve and Mixer must be installed together.</i>	*
Air trap valve	A valve that directs the flow through the Air trap, or bypasses the Air trap, for example when using low flow rates. The air trap valve includes an air sensor.  The air sensor detects air coming out from the Air trap (empty Air trap) or if the Air trap is bypassed, the sensor detects air in the flow path.  In order to prevent air from reaching the column an air sensor alarm can be enabled that pauses the run.	
Air trap	The air trap removes air bubbles from the flow path. It enhances system performance and prevents air from degrading column performance.	
Column valve	A valve that allows the connection of two columns, or one column and a Superloop™ for sample application.  Flow direction in the columns can be either upflow or downflow. It is possible to run the two columns in series.  The columns can be bypassed one by one or both. The flow can also be directed to waste.  One of the column positions can be used to connect a Superloop for sample loading.  In addition, the column valve can also be used for Intelligent column Packing (IP).  The column valve includes pre-column and post-column pressure sensors.	
Conductivity monitor	The conductivity monitor is used to verify gradients and to follow peak positions relative to ionic strength. The conductivity monitor includes a temperature sensor.	
Pre-column conductivity monitor	A conductivity monitor that can be added before the column valve. The pre-column conductivity monitor includes a temperature sensor.	*

### 3 System description

#### 3.4 Available modules for ÄKTA pilot 600

Module	Description	Optional
UV monitor	The UV monitor is used to measure the UV/Vis absorbance at up to three wavelengths in the range 190-700 nm.	
pH monitor	The pH monitor is used to continuously measure the pH of solutions used in the run.	*
Outlet valve 1-3	Outlet valve which directs the flow to any of the three outlet ports, <b>W/1</b> , <b>2</b> or <b>3</b> . The <b>W/1</b> port is normally used for waste.	
Outlet valve 4-6	Outlet valve for ports <b>4</b> to <b>6</b> <b>Note:</b> <i>Outlet valve 1-3 must be installed.</i>	*
Outlet valve 7-9	Outlet valve for ports <b>7</b> to <b>9</b> . <b>Note:</b> <i>Outlet valves 1-3 and 4-6 must be installed.</i>	*
Outlet valve 10-12	Outlet valve for ports <b>10</b> to <b>12</b> . <b>Note:</b> <i>Outlet valves 1-3, 4-6, and 7-9 must be installed.</i>	*
Outlet valve 13-15	Outlet valve for ports <b>13</b> to <b>15</b> . <b>Note:</b> <i>Outlet valves 1-3, 4-6, 7-9, and 10-12 must be installed.</i>	*

### External air sensors

Up to four air sensors can be installed between the buffer or sample containers and the inlet valves. The external air sensors can be used to detect empty containers and to change inlet ports, for continued supply of sample or buffer, or to pause the run.



Part	Description
1	UniNet-9 cable: connect to a free <b>UniNet-9</b> connector on the rear panel of the instrument
2	Port for SNAP connector
3	Port for SNAP connector

The external air sensors are numbered 1 to 4 from the factory. A label showing the number is attached to the cable. The number identifies each external air sensor in the UNICORN software.

## 3.5 In-line filters

### Introduction

Two alternative solutions are available for in-line filters for ÄKTA pilot 600 system:

- Filter cassettes mounted in a stainless steel housing
- Disposable ULTA™ Capsule CG filters from Cytiva, mounted in a filter holder

Both the stainless steel housing and the filter holder are optional accessories.

This section describes the essential characteristics of the two alternatives. In both cases, replacement of the filter is recommended after every run.

### Steel filter housing (optional)

The stainless steel filter housing is designed for filter cassettes with a bayonet fitting with outer diameter 39.5 mm. Maximum cassette length is 2.5 in (65 mm).

Cassettes are not provided with the ÄKTA pilot 600 system, and must be obtained from a third party supplier. PEPLYN PLUS or PROPOR BP filters from Parker Hannifin Corporation are recommended.

The steel housing withstands pressures up to 20 bar. Cassettes are available in a range of materials and pore sizes.

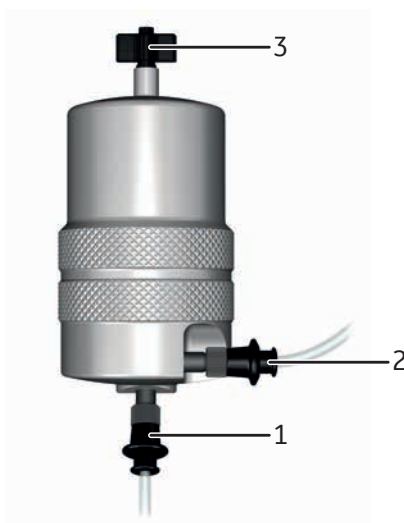

Part	Description
1	Outlet
2	Inlet
3	Air vent



## Filter holder for ULTA filters (optional)

The ÄKTA pilot 600 ULTA CG filter mounting kit is designed for ULTA Capsule CG filters with 2" length. ULTA filters can be ordered separately from Cytiva.

ULTA filters operate at a maximum pressure of 5 bar g.



### WARNING

When ULTA filters are used, the system pressure alarm must be set to a maximum of 5 bar in the UNICORN software **System Settings**.

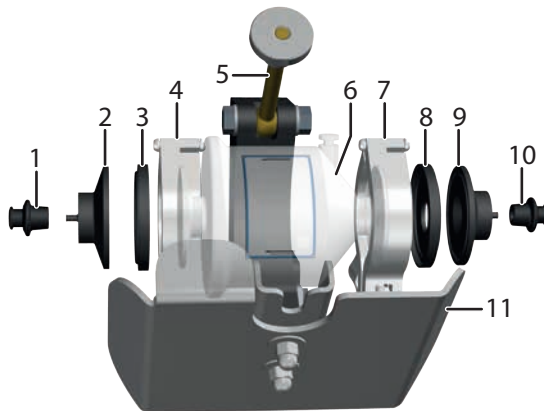

Part	Description
1	SNAP connector, outlet
2	TC 50 to SNAP connector fitting
3	Seal
4	TC 50 clamp
5	Locking bar
6	ULTA Capsule CG filter (not included in the mounting kit)
7	TC 50 clamp
8	Seal
9	TC 50 to SNAP connector fitting
10	SNAP connector, inlet
11	Protective guard

## 3.6 Accessories

### Introduction

Basic accessories are delivered with the ÄKTA pilot 600 instrument. Optional accessories are available from Cytiva. This section describes the available accessories.

### Accessories included with the ÄKTA pilot 600 instrument

The following accessories are delivered with the instrument:

- SNAP connectors, 3.2 mm and 4.8 mm
- Adapter, TC 25 to 3.2 mm SNAP connector
- Adapter, TC 25 to 4.8 mm SNAP connector
- Adapter, 5/16 in threaded male connector to 3.2 mm SNAP connector
- Stop plugs for 3.2 mm SNAP connector
- Reference capillary
- Tubing cutter
- Tube bender
- Tool for module retaining screw

### Optional accessories

The following optional accessories are available:

- Extension box for optional modules
- Extension stand for columns and accessories
- I/O-box to connect external equipment to the ÄKTA pilot 600 instrument

## Extension box for optional modules

Optional modules can be installed in an Extension box that can be placed on the bench beside the instrument, or attached to the Extension stand.

The following illustration shows a module installed in an Extension box.

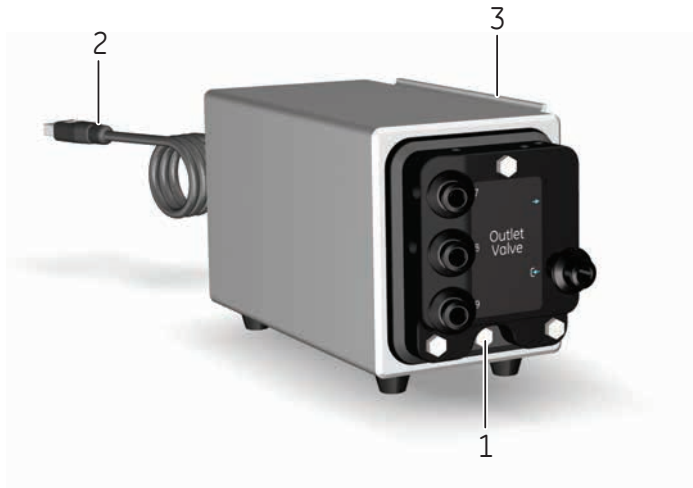

Part	Description
1	Retaining screw for the module
2	UniNet-9 cable: connect to a free <b>UniNet-9</b> connector at the back of the instrument
3	Bracket for hanging the Extension box on the Extension stand

**Note:** The enclosure protective class for the Extension box is IP 21.

**Note:** If the Extension box is used with ÄKTA pilot 600R, the Product Documentation for the instrument will be invalid.

### 3 System description

#### 3.6 Accessories

## Extension stand for columns and accessories

The Extension stand can be used to mount columns, the Extension box, and the I/O-box. The stand includes holders to organize the tubing.

The following illustration shows the Extension stand with a column attached.



## I/O-box

The external I/O-box can be used to connect other equipment in order to measure parameters such as refractive index, light scattering and fluorescence. The I/O-box can communicate with external equipment by digital or analog signals.

The I/O-box can be attached to the Extension stand or placed on the bench, using the supplied feet. The I/O-box fulfils enclosure protective class IP23 when mounted in the correct position on the Extension stand. In all other situations the I/O-box fulfils IP20.



### NOTICE

The I/O-box should be located away from any liquids.

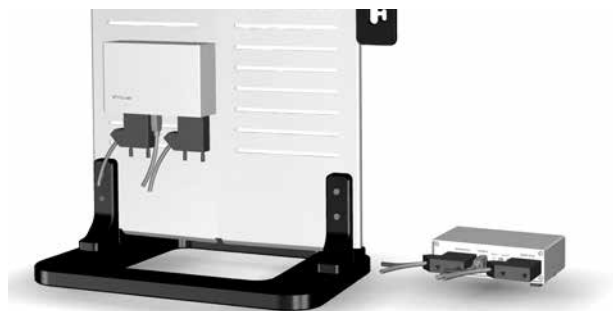

## 3.7 Description of the flow path

### Introduction

This section gives an overview of the flow path in the ÄKTA pilot 600 instrument.

### Flow diagram

The following illustration shows a schematic diagram of the flow path. Optional components are marked with dashed outlines.

For ÄKTA pilot 600R, all components must be installed in the instrument chassis. Contact your Cytiva representative for more information about possible configurations.

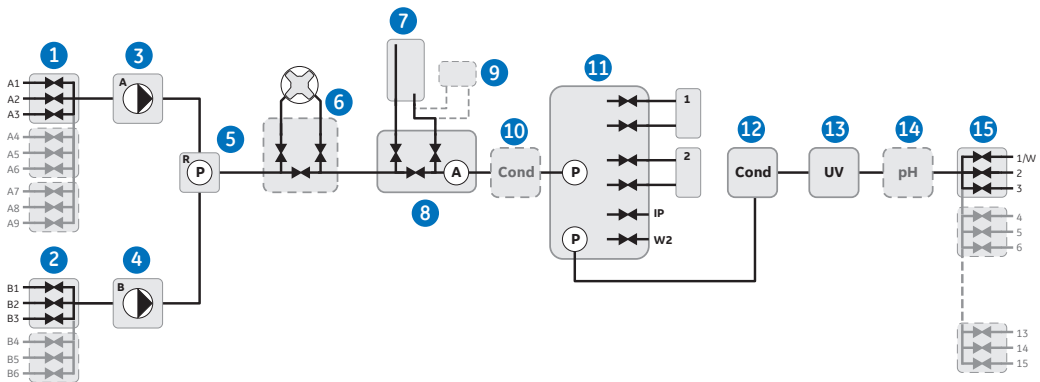

Part	Function
1	Inlet valve A with 3 ports. Can be expanded to 9 ports with optional inlet valves.
2	Inlet valve B with 3 ports. Can be expanded to 6 ports with optional inlet valves.
3	System pump A
4	System pump B
5	Flow restrictor and system pressure sensor
6	Mixer and mixer valve (optional)
7	Air trap
8	Air trap valve including air sensor
9	In-line filter (optional)

Part	Function
10	Pre-column Conductivity monitor with temperature sensor (optional)
11	Column valve including pre-column and post-column pressure sensors
12	Conductivity monitor with temperature sensor
13	UV monitor
14	pH module (optional)
15	Outlet valve with 3 ports. Can be expanded to 15 ports with optional outlet valves.

### Adding external air sensors to the flow path

External air sensors can be added before the A or B inlets, as shown in the following flow diagram. For information about installing external air sensors, see [Section 4.2.7 Install optional external air sensors, on page 88](#).

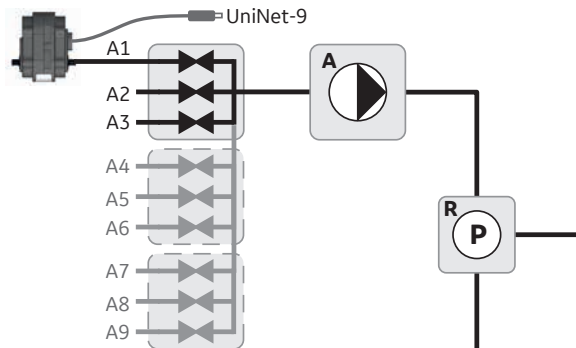

## 3.8 UNICORN system control software

### About this section

This section gives a brief overview of the UNICORN software and the **System Control** module that is used to control chromatography runs.

For full documentation of the software, see the UNICORN user documentation.

### In this section

Section	See page
3.8.1 UNICORN software overview	49
3.8.2 The System Control module	50



## 3.8.1 UNICORN software overview

### Introduction

This section gives a brief overview of the UNICORN software: a complete package for control, supervision and evaluation of chromatography instruments and purification runs.

In this manual, UNICORN refers to compatible versions of the software. The examples given in this manual are from UNICORN 7.3.

### UNICORN modules overview

UNICORN consists of four modules: **Administration**, **Method Editor**, **System Control** and **Evaluation**. The main functions of each module are described in the following table.

Module	Main functions
<b>Administration</b>	Perform user and system setup, system log and database administration.
<b>Method Editor</b>	<p>Create and edit methods using one or a combination of:</p> <ul style="list-style-type: none"> <li>• Predefined methods with built-in application support</li> <li>• Drag-and-drop function to build methods with relevant steps</li> <li>• Line-by-line text editing</li> </ul> <p>The interface provides easy viewing and editing of run properties.</p>
<b>System Control</b>	Start, monitor and control runs. The current flow path is illustrated in the <b>Process Picture</b> , which allows manual interactions with the system and provides feedback on run parameters.
<b>Evaluation</b>	<p>Open results, evaluate runs and create reports.</p> <p>The <b>Evaluation</b> module includes a user interface optimized for workflows such as quick evaluation, comparing results and working with peaks and fractions. Advanced features requires <b>Evaluation Classic</b>, available from Cytiva.</p>

When working with the modules **Administration**, **Method Editor**, **System Control** and **Evaluation** it is possible to access descriptions of the active window or software instruction by pressing the **F1** key. This can be especially helpful when editing methods.

## 3.8.2 The System Control module

### Introduction

The **System Control** module is used to start, monitor, and control a manual or method run.

### Illustration of the System Control user interface

















The illustration below shows the different panes and areas of the **System Control** module.



Part	Description
1	Toolbar buttons for quick access to instrument controls. For descriptions, see <i>System Control toolbar buttons</i> below.
2	<b>Chromatogram:</b> illustrates data as curves.
3	<b>Process Picture:</b> illustrates the current flow path. The <b>Process Picture</b> allows manual interactions with the system and provides feedback on component status and run parameters.
4	<b>Run Log:</b> All registered actions during the run are displayed in the <b>Run Log</b> pane.
5	<b>Status bar:</b> shows information on instrument and database connection.

## System Control toolbar buttons

The following table shows the **System Control** toolbar buttons that are referred to in this manual.

Button		Function
UNICORN software version		
Up to 7.3	7.4 and later	
		<b>Open Method Navigator.</b> Opens the <b>Method Navigator</b> where available methods are listed.
		<b>Hold.</b> Suspends the method run, while current flow rate and valve positions are sustained.
		<b>Continue.</b> Resumes a held or paused method run.
		<b>Customize.</b> Opens the <b>Customize</b> dialog box where curve settings, run data groups and run log contents can be set.
		<b>Run.</b> Starts a method run.
		<b>Pause.</b> Suspends the method run and stops all pumps.
		<b>End.</b> Permanently ends the method run.
		<b>Connect to Systems.</b> Opens the <b>Connect to Systems</b> dialog box where systems can be connected, and currently connected users are displayed.

### 3 System description

#### 3.8 UNICORN system control software

##### 3.8.2 The System Control module

### Process Picture overview

Manual operations can be performed either via the **System Control** menu or the **Process Picture**. Each flow path component is represented by a box that displays the state of the component.

The following illustration describes the different parts of the **Process Picture**. For further information on how to use the **Process Picture** see [Chapter 5 Prepare the system for a run, on page 120](#).

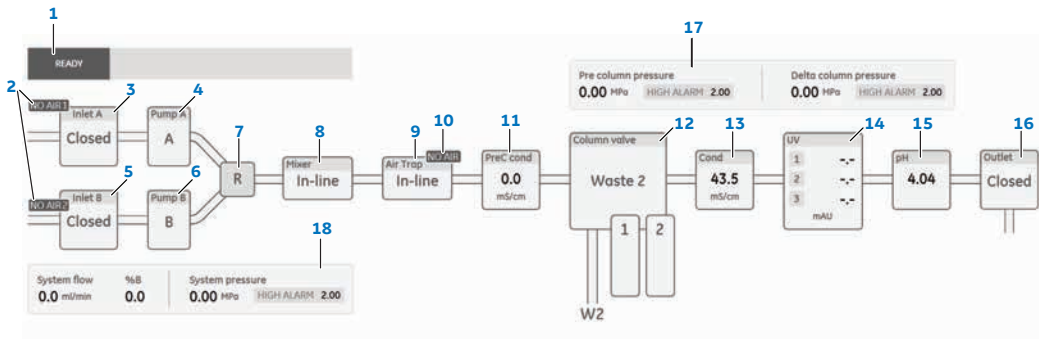



Part	Function
1	System state pane. Indicates the current system state: <b>Ready, Manual Run, Method Run, Pause</b> . During a method run, the right-hand part of the System state pane shows which part of the method that is currently running.
2	<b>NO AIR1, NO AIR2</b> : Indicators for external air sensors (up to four external air sensors can be used).  If air is detected by external air sensor 1, the indicator shows <b>AIR1</b> on a red background:  
3	<b>Inlet A</b> : up to 9 inlet ports, depending on the number of installed Inlet valves. If Inlet A is closed, <b>Closed</b> is displayed in the box. If Inlet A is open, the selected port is shown: <b>A1, A2, ..., A9</b> .
4	<b>Pump A</b> : System pump A. When the pump is operating, the flow path is shown as a green line.
5	<b>Inlet B</b> : Up to 6 inlet ports, depending on the number of installed Inlet valves. If Inlet B is closed, <b>Closed</b> is displayed in the box. If Inlet B is open, the selected port is shown: <b>B1, B2, ..., B6</b> .
6	<b>Pump B</b> : System pump B. When the pump is operating, the flow path is shown as a green line.
7	<b>R</b> : Flow restrictor and system pressure monitor.

Part	Function
8	<b>Mixer</b> valve (optional). The state of the Mixer valve is shown in the box: <b>In-line</b> or <b>By-pass</b> .
9	<b>Air Trap</b> valve. The state of the Air Trap valve is shown in the box: <b>In-line</b> or <b>By-pass</b> .
10	<b>NO AIR</b> (NO AIR): Indicator for built-in air sensor. As long as no air is detected, the air sensor indicator shows <b>NO AIR</b> on a black background. If air is detected, the indicator shows <b>AIR</b> on a red background:  <b>Note:</b> <i>The air sensor detects air coming out from the Air trap (empty Air trap) or if the Air trap is bypassed, the sensor detects air in the flow path.</i>
11	<b>PreC cond</b> : Pre-column conductivity monitor (optional). The measured conductivity is displayed in the box.
12	<b>Column Valve</b> : Column valve, where column positions are indicated by <b>1</b> and <b>2</b> . The state of the Column valve is shown in the box, for example <b>Waste 2, Column 1 downflow</b> . The default state is <b>Waste 2</b> .
13	<b>Cond</b> : Conductivity monitor. The measured conductivity is displayed in the box.
14	<b>UV</b> : UV monitor. The measured UV/Vis absorbance is displayed in the box (three wavelengths).
15	<b>pH</b> : pH monitor (optional). The measured pH is displayed in the box.
16	<b>Outlet</b> : up to 15 outlet ports, depending on the number of installed Outlet valves. If the outlet path is closed, <b>Closed</b> is shown in the box. If the outlet path is open, the selected port is shown: <b>W/1, 2, 3, ..., 15</b> .
17	Column pressure pane: displays the <b>Pre Column</b> and <b>Delta Column</b> pressures. Alarm levels can be set for each of the pressures.
18	System flow and pressure pane: displays <b>System Flow</b> , <b>%B</b> , and <b>System Pressure</b> . An alarm level can be set for <b>System Pressure</b> .

## Color indications of the flow path state

The flow path state is indicated by color, as described in the following table.

Color	Indication in <i>Process Picture</i>	Flow path state
Gray		Closed flow path
Green dashed		Open flow path without flow
Green		Open flow path with flow

## Example of dialog in the Process Picture

For applicable flow path components, you can access settings by clicking the component in the **Process Picture**. The following illustration shows the dialog that appears when you click **Inlet A**.

To open an inlet port, click one of the Valve Position buttons **A1** to **A3**. The number of inlet ports depends on the number of installed inlet valves.

To close the inlet, click **Close**.

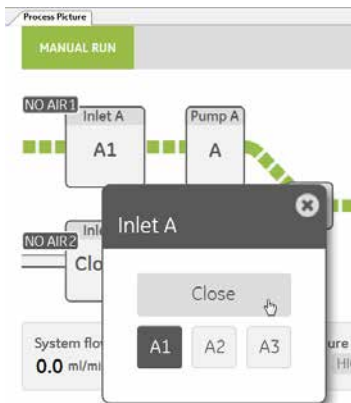

# 4 Installation

## About this chapter

This chapter provides required information to enable users and service personnel to unpack, install, move and transport the ÄKTA pilot 600 system.

## In this chapter

Section	See page
4.1 Site preparation	56
4.2 Installing the ÄKTA pilot 600 system	67
4.3 Connecting the system units	106
4.4 Installing UNICORN software	108
4.5 Connecting the ÄKTA pilot 600 instrument to UNICORN software	109
4.6 Performance tests	114
4.7 Delay volumes	115
4.8 Moving the ÄKTA pilot 600 system	117

## 4 Installation

### 4.1 Site preparation

## 4.1 Site preparation

### Introduction

This section describes the site planning and preparation that should be performed before the ÄKTA pilot 600 system is installed.

### In this section

<b>Section</b>	<b>See page</b>
4.1.1 Delivery, storage and unpacking	57
4.1.2 Room requirements	59
4.1.3 Site environment	62
4.1.4 Power requirements	64
4.1.5 Computer requirements	66



## 4.1.1 Delivery, storage and unpacking

### Introduction

This section describes the requirements for receiving the delivery box and storing the instrument before installation.



#### **WARNING**

**Heavy object.** Use suitable lifting equipment when moving the instrument. Four people are required to lift the system safely. All lifting and moving must be performed in accordance with local regulations.

### When you receive the delivery

- Record on the receiving documents if there is any apparent damage on the delivery box. Inform your Cytiva representative of such damage.
- Move the delivery box to a protected location indoors.

### Delivery box

ÄKTA pilot 600 instruments are shipped in a delivery box with the following dimensions and weight:

Contents	Dimensions (mm)	Weight
ÄKTA pilot 600 instrument with accessories	765 × 1055 × 640 (width × height × depth)	109 to 115 kg <sup>1</sup>

<sup>1</sup> Depending on the configuration

### Storage requirements

The delivery boxes should be stored at a protected place indoors. The storage place for unopened boxes must meet the following requirements:

Parameter	Allowed range
Ambient temperature, storage	-25°C to 60°C
Relative humidity	20% to 95%, noncondensing

### Transportation equipment

The following equipment is recommended for handling the delivery boxes:

## 4 Installation

### 4.1 Site preparation

#### 4.1.1 Delivery, storage and unpacking

Equipment	Specifications
Pallet mover	Suitable for a lightweight pallet 80 × 100 cm 
Cart for transporting the instrument to the lab	Dimensioned to accommodate the size and weight of the instrument

## Unpacking the ÄKTA pilot 600 instrument

For information on how to unpack the ÄKTA pilot 600 instrument and how to lift the instrument onto a laboratory bench see *ÄKTA pilot 600 Unpacking Instructions*.

## 4.1.2 Room requirements

### Introduction

This section describes the requirements for the room where the ÄKTA pilot 600 instrument is placed.

### Instrument dimensions and weight

The outer dimensions of the ÄKTA pilot 600 instrument are shown in the following illustration.



The standard system with no optional modules weighs 78 kg (excluding computer and monitor). Optional modules may weigh a total of up to approximately 6 kg.

### Space requirements

ÄKTA pilot 600 system can be installed on a standard laboratory bench or on a trolley with wheels. Make sure there is adequate working space beside the instrument.

Prepare a clean working area on a stable laboratory bench or trolley that complies with the specifications in the following table. There must be sufficient space to turn the instrument on the bench for service access to the rear panel.

A typical setup is shown in the illustration below.

## 4 Installation

### 4.1 Site preparation

#### 4.1.2 Room requirements



Parameter	Specification
Minimum bench area for operating ÄKTA pilot 600 (D x W)	60 x 70 cm <sup>1</sup>
Minimum bench load capacity	100 kg <sup>2</sup>
Inclination of bench surface	Horizontal $\pm 2^\circ$

<sup>1</sup> Excluding work area and area for computer. Additional depth may be required on a fixed bench to enable service access to the back of the instrument.

<sup>2</sup> Excluding buffer and waste containers



#### **WARNING**

**Access to power cord.** Do not block access to the power cord. The power cord must always be easy to disconnect.



#### **CAUTION**

**Tipping risk.** Before moving the instrument on a trolley, secure the instrument using straps with a minimum strength of 100 kg.



#### **CAUTION**

If the product is installed on a trolley, keep the trolley wheels locked at all times except when moving the product.

**Note:** *When preparing the bench area for the installation, make sure that the power cord will be easy to access and disconnect.*

## Liquid containers

Place buffer containers (**B**) on the bench or on a shelf under the instrument. Do not place buffer containers higher than the highest point of the instrument. Place waste containers (**W**) so that the outlet is below the lowest point of the instrument.

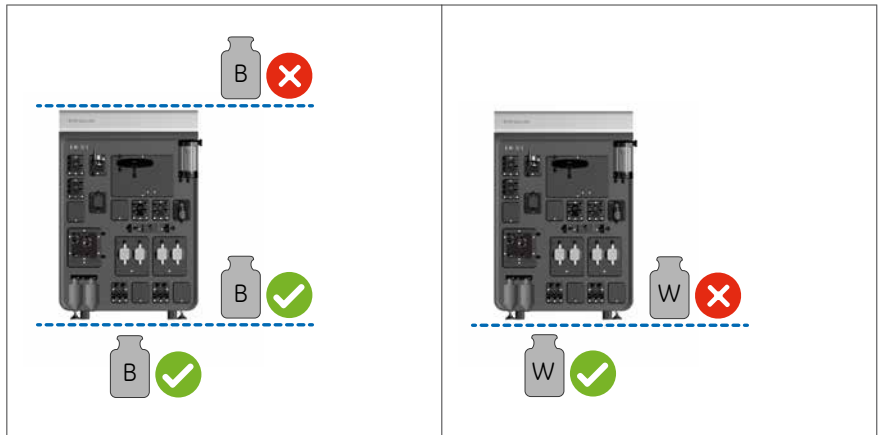

**Note:** *Depending on the scale and frequency of runs, large buffer and waste containers may be required.*

### 4.1.3 Site environment

#### Introduction

This section describes the environmental requirements and conditions for installation of the ÅKTA pilot 600 system.

#### Environmental requirements

The installation site must comply with the following specifications.

Parameter	Requirement
Allowed location	Indoor use only
Ambient temperature, operating	4°C to 35°C
Ambient temperature, storage	-25°C to 60°C
Relative humidity, operating	20% to 95%, non-condensing
Relative humidity, non-operating	20% to 95%, non-condensing
Altitude, operating	Up to 2000 m <sup>1</sup>
Pollution degree of the intended environment	Pollution degree 2

<sup>1</sup> If the installation is situated at a higher altitude, the customer is responsible for establishing that the ÅKTA pilot 600 instrument can be used safely in accordance with local regulations.

#### Environmental conditions

The following general requirements must be fulfilled:

- The room must have exhaust ventilation.
- The instrument should not be exposed to direct sunlight.
- Dust in the atmosphere should be kept to a minimum.

#### Instrument ventilation

There should be at least 10 cm clearance at the back of the instrument to allow adequate air circulation.



#### NOTICE

Do not block the air vents on the rear of the instrument.

## Heat output

The heat output data is listed in the table below.

Component	Heat output
ÄKTA pilot 600 instrument	Typically 500 W Maximum 800 W
Computer, including monitor and printer	Typically 300 W Refer to manufacturer's specifications for more information.
Total	Typically 800 W Maximum 1100 W

## 4.1.4 Power requirements

### Introduction

This section describes the electrical power requirements for the ÄKTA pilot 600 instrument.



#### **WARNING**

**Protective ground.** The product must always be connected to a grounded power outlet.



#### **WARNING**

**Power cord.** Only use power cords with approved plugs delivered or approved by Cytiva.

### Electrical power requirements

The following table specifies the power requirements for the ÄKTA pilot 600 instrument. For power requirements for the computer, refer to the manufacturer's specifications.

Parameter	Requirement
Supply voltage	100 to 240 V~
Frequency	50/60 Hz
Type of distribution system	TN
Power outlet type	Grounded mains outlets
Transient overvoltages	Overvoltage category II
Max power consumption	800 VA

### Power quality

The mains power supply must be stable and conform to specifications at all times to ensure reliable operation of the ÄKTA pilot 600 instrument. There should be no transient or slow changes in average voltage outside the limits specified above.

### Uninterruptible power supply (UPS)

Connecting the system to a UPS can prevent data loss during a power failure, and allow time for a controlled shutdown of ÄKTA pilot 600.



For UPS power requirements, see the system specifications in this manual. Remember to also take into account the specifications for the computer and monitor. Refer to the manufacturers' documentation.

**Note:** *If a UPS is used, both the ÄKTA pilot 600 instrument and computer should be connected to the UPS.*

## 4.1.5 Computer requirements

### General requirements

ÄKTA pilot 600 systems are controlled by UNICORN software running on an external PC. The computer is not included with the ÄKTA pilot 600 instrument.

A suitable computer may be ordered from Cytiva or obtained from a third party supplier.

General requirements and recommended specifications of the computer are given at [cytiva.com/UNICORNPCspecifications](https://www.cytiva.com/UNICORNPCspecifications).



#### NOTICE

Any computer used with the equipment must comply with IEC 60950 and be installed and used according to the manufacturer's instructions.



#### NOTICE

When installing a computer, make sure that it is installed with appropriate protection for the intended environment that might expose the computer to liquids and moisture.

**Note:** *Any computer used with the equipment must comply with IEC 60950 and be installed and used according to the manufacturer's instructions.*

**Note:** *When installing a computer, make sure that it is installed with appropriate protection for the intended environment that might expose the computer to liquids and moisture.*

### Network connection requirements

If the computer is to be connected to a network, two Ethernet ports are required, one for connection to the ÄKTA pilot 600 instrument and one for connection to a network.

Network settings are described in [Network settings, on page 71](#).

## 4.2 Installing the ÄKTA pilot 600 system

### About this section

This section describes the procedure for installing the ÄKTA pilot 600 system.

### In this section

Section	See page
4.2.1 Introduction	69
4.2.2 Install the instrument and computer	70
4.2.3 Fit inlet and outlet tubing	72
4.2.4 Install the Air Trap	79
4.2.5 Install the pump rinsing system	82
4.2.6 Fit the pH electrode	84
4.2.7 Install optional external air sensors	88
4.2.8 Install the optional steel filter housing	90
4.2.9 Install the optional ULTA filter	94
4.2.10 Install and uninstall optional modules	99

### Precautions



#### WARNING

**Heavy object.** Use suitable lifting equipment when moving the instrument. Four people are required to lift the system safely. All lifting and moving must be performed in accordance with local regulations.



#### WARNING

**Power cord.** Only use power cords with approved plugs delivered or approved by Cytiva.

## 4 Installation

### 4.2 Installing the ÄKTA pilot 600 system



#### **WARNING**

**Protective ground.** The product must always be connected to a grounded power outlet.



#### **WARNING**

**Access to power plug.** Do not block access to the power outlet and power plug. The power cord with plug must always be easy to disconnect.

## 4.2.1 Introduction

The Regulatory system is delivered with optional modules pre-installed, except for the items listed below.

Optional modules purchased with the Standard system must be installed by the user. Instructions for installing the modules are provided with the modules themselves.

Items listed in the table below are packaged separately for protection in both Regulatory and Standard systems, and must be fitted by the user as part of the system installation.

Module	Comment
Air trap	See <a href="#">Section 4.2.4 Install the Air Trap, on page 79</a> .
Pump rinsing holder and bottles	See <a href="#">Section 4.2.5 Install the pump rinsing system, on page 82</a> .
External air sensors (optional)	See <a href="#">Section 4.2.7 Install optional external air sensors, on page 88</a> .
Filter housing (optional)	See <a href="#">Section 4.2.8 Install the optional steel filter housing, on page 90</a> .
ULTA filter holder (optional)	See <a href="#">Section 4.2.9 Install the optional ULTA filter, on page 94</a> .
pH electrode (when optional pH monitor is included)	The pH electrode is packaged separately for protection and must be fitted if the pH monitor is included in the system (see <a href="#">Section 4.2.6 Fit the pH electrode, on page 84</a> ).

## 4 Installation

### 4.2 Installing the ÄKTA pilot 600 system

#### 4.2.2 Install the instrument and computer

## 4.2.2 Install the instrument and computer

### Requirements

See [Section 4.1.5 Computer requirements, on page 66](#) for computer requirements.

### Place the instrument on the bench

Place the instrument on the bench (see [Space requirements, on page 59](#) for space requirements). Use the lifting handles under the instrument (indicated in the illustration below) to lift the instrument.



#### WARNING

**Heavy object.** Use suitable lifting equipment when moving the instrument. Four people are required to lift the system safely. All lifting and moving must be performed in accordance with local regulations.

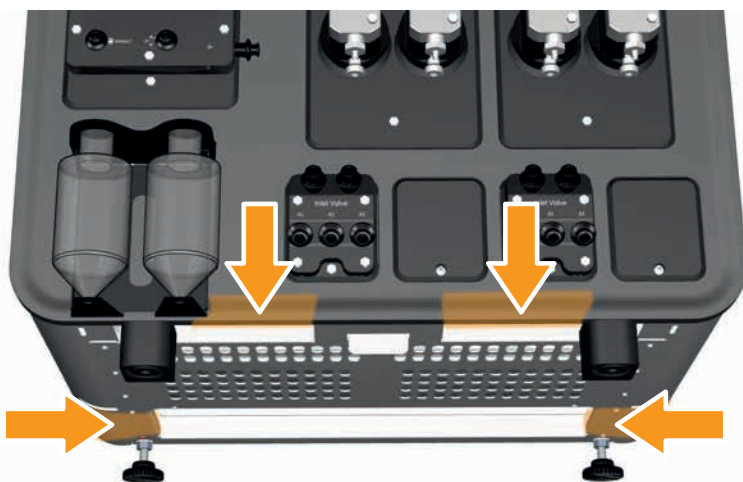

Use the adjustable rear feet to compensate for any unevenness in the bench surface.

**Note:** Do not lift the instrument using the frame at the lower rear of the instrument.

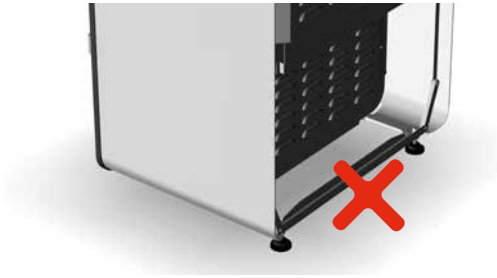

## Securing the instrument on the bench

The ÄKTA pilot 600 instrument can be secured on the bench or table, for example, in earthquake-prone regions or when the instrument is installed on a movable table. Contact Cytiva for assistance if this is required.

## Install the computer equipment

Unpack and install the computer according to the manufacturer's instructions.

## Network settings

Computers used with the ÄKTA pilot 600 instrument require two Ethernet ports, one for communication with the local network and one dedicated to communication with the ÄKTA pilot 600 instrument. Computers purchased with the system from Cytiva are preconfigured on delivery.

Set the properties of the Ethernet port dedicated to the ÄKTA pilot 600 instrument as listed below. Contact your IT department or equivalent if you need help.

Parameter	Setting
IPv4 address	172.16.0.2 <sup>1</sup>
Subnet mask	255.255.255.0
DHCP enabled	No

<sup>1</sup> If this address conflicts with other IP addresses in the network, contact Cytiva Service for assistance.

## 4 Installation

### 4.2 Installing the ÄKTA pilot 600 system

#### 4.2.3 Fit inlet and outlet tubing

## 4.2.3 Fit inlet and outlet tubing

### Introduction

The following tubing must be fitted:

- Inlet tubing (i.d. 4.8 mm)
- Outlet tubing (i.d. 3.2 mm)
- Waste tubing (i.d. 3.2 mm)

See [Section 3.3 Tubing and connectors, on page 33](#) for details of how to use tubing and SNAP connectors.

### Required material

The following materials are required:

- Tubing
- SNAP connectors for 3.2 and 4.8 mm i.d. tubing
- Tubing cutter



#### CAUTION

**Sharp tool.** The tubing cutter is very sharp and can cause injuries if it is not handled with care.

### Using the tubing cutter

Follow the instructions below to cut a piece of tubing.

Step	Action
------	--------

- |   |   |
|---|---|
| 1 | Squeeze the short grip to open the tubing cutter. |
|---|---|

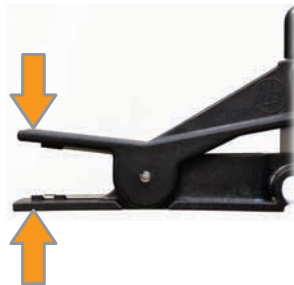

- |   |   |
|---|---|
| 2 | Insert the tubing end into the hole in the tubing cutter. |
|---|---|



Step	Action
3	Hold the tubing with one hand and rotate the tubing cutter around the tubing with the other hand until the tubing is cleanly cut. Do not squeeze the grip.



## Using the Tube bender

The Tube bender, provided as an accessory with the instrument, helps in bending tubing without introducing kinks. Short lengths of tubing, especially the i.d. 4.8 mm tubing on the inlet side of the pumps, are particularly susceptible to kinking.

Use the Tube bender as described in the steps below.

Step	Action
1	Mount the Tube bender on mounting pins on the front of the instrument, for example, the mounting pins for the in-line filter holder.  The Tube bender can also be used while held in the hand.
2	Pull the tubing around the groove in the Tube bender until a suitable bend is obtained. Use the wider groove for i.d. 4.8 mm tubing and the narrower for i.d. 3.2 mm tubing.

## Attach tubing to a module

Follow the instructions below to attach a piece of tubing to a port on the front of a module.

**Tip:** Use the Tube bender if necessary to create smooth bends in the tubing and avoid kinks.

## 4 Installation

### 4.2 Installing the ÄKTA pilot 600 system

#### 4.2.3 Fit inlet and outlet tubing

Step	Action
------	--------

- |   |   |
|---|---|
| 1 | Make sure that the tubing end is cut at a right angle and that the surface is not damaged. If needed, cut off a short length of the tubing with the tubing cutter included with the system. |
|---|---|



#### CAUTION

**Sharp tool.** The tubing cutter is very sharp and can cause injuries if it is not handled with care.

- |   |   |
|---|---|
| 2 | On a new instrument: remove the protective sheath from the inlet or outlet port to be used. |
|---|---|

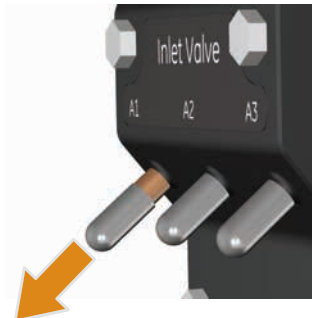

- |   |   |
|---|---|
| 3 | Insert the tubing into and through the connector: |
|---|---|

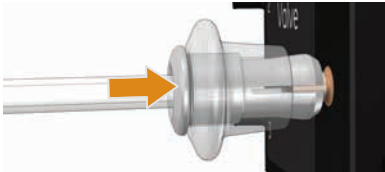
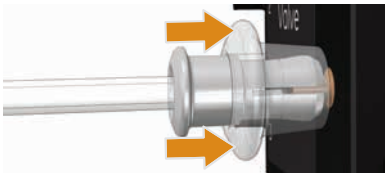

Step	Action
4	Press the tubing end onto the nipple, and push it all the way to the module front.
	
5	Press the center part of the connector against the module front until it snaps into place.
	
6	Press the sleeve until it snaps into place and locks the connection.
	
7	Make sure that the tubing is not stretched or kinked.
8	Run a test after connecting the tubing, to make sure that there is no leakage.

## Disconnect tubing from a module



### CAUTION

Always click **End** before before disconnecting any tubing, to release all remaining pressure in the flow path. If the air trap is filled it is recommended that you empty the air trap by selecting **Start Drain** in the **Air Trap Valve** dialog box in the **Process Picture**.

Follow the instructions below to disconnect and remove a piece of tubing from a module.

## 4 Installation

### 4.2 Installing the ÄKTA pilot 600 system

#### 4.2.3 Fit inlet and outlet tubing

Step	Action
1	Pull the sleeve to release the connector, while pushing lightly at the connector with the thumb.
	
2	Remove the tubing from the nipple.
	

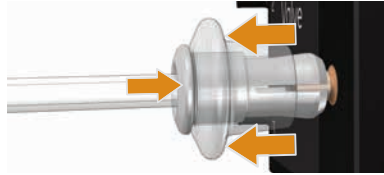



## Fit the waste tubing

ÄKTA pilot 600 has two waste outlet ports, one from the outlet valve (**Waste**) and one from the column valve (**Waste 2**). Waste tubing should be fitted to both ports.

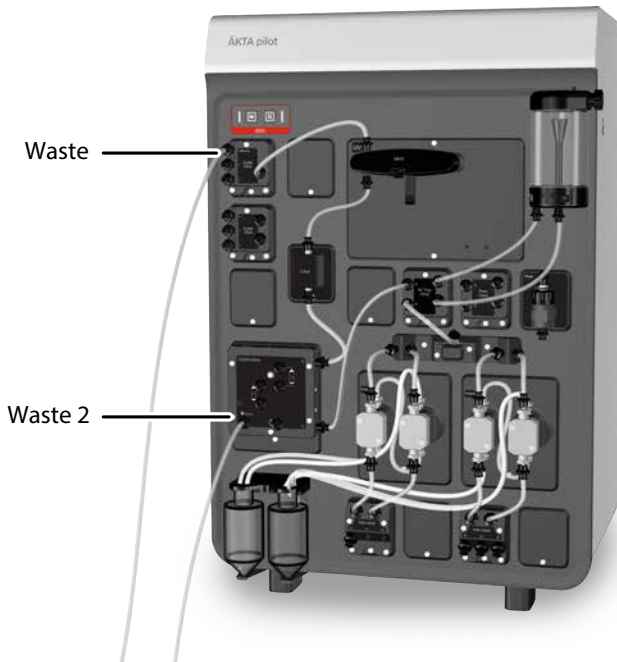

Follow the instructions below to prepare the waste tubing.

Step	Action
1	Cut the waste tubing (i.d. 3.2 mm) long enough to ensure proper insertion into the waste container without becoming kinked.
2	Remove the protective dust caps from the waste outlet(s).
3	Fit a SNAP connector to one end of the tubing and connect the tubing to the waste ports (see <a href="#">Attach tubing to a module, on page 73</a> ).
4	Place and secure the waste tubing from the <b>Waste</b> and the <b>Waste 2</b> ports in a suitable waste container. The end of the waste tubing should be below the lowest point on the instrument.



#### CAUTION

Make sure that the waste container is dimensioned for maximum possible volume when the equipment is left unattended.

## Fit the inlet and outlet tubing

Follow the instructions below to fit the inlet and outlet tubing.

Step	Action
1	Cut suitable lengths of inlet tubing (i.d. 4.8 mm) and outlet tubing (i.d. 3.2 mm) using the tubing cutter.
2	Remove the protective dust caps from the waste outlet(s).
3	Fit SNAP connectors to one end of each piece of tubing and connect the tubing to the inlet (A) and outlet (B) ports as required.

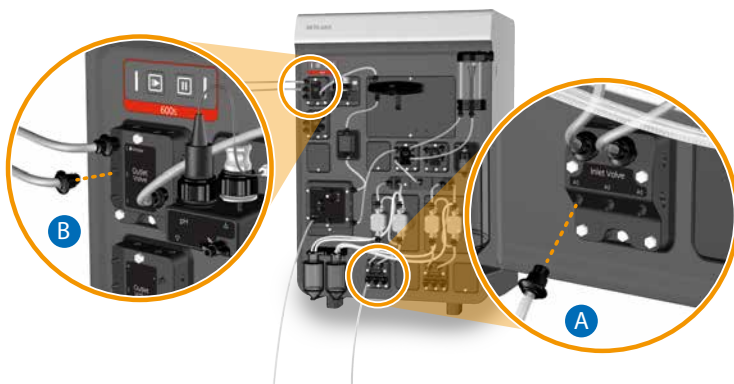

## 4 Installation

### 4.2 Installing the ÄKTA pilot 600 system

#### 4.2.3 Fit inlet and outlet tubing

<b>Step</b>	<b>Action</b>
4	Secure the other end of the tubing in the respective container. The container should not be above the highest point of the instrument.



#### **CAUTION**

Secure all outlet tubing carefully so that it remains in the container even when high flow rates cause vibrations in the tubing.

## 4.2.4 Install the Air Trap

### Introduction

The **Air Trap** is supplied in a separate box inside the main delivery crate, and must be installed before the ÄKTA pilot 600 instrument can be used. The **Air Trap** (A) is mounted at the top right of the instrument front panel (B).

Tubeing and connectors for the **Air Trap** inlet and outlet are fitted to the Air Trap Valve on delivery.

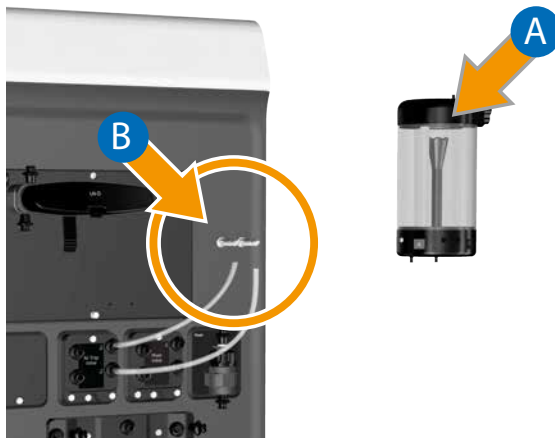

**Note:** The transparent outer splash guard on the **Air Trap** is loose by design.

### Installation procedure

Follow the instructions below to install the **Air Trap**.

## 4 Installation

### 4.2 Installing the ÄKTA pilot 600 system

#### 4.2.4 Install the Air Trap

Step	Action
------	--------

- |   |  |
|---|--|
| 1 | Align the holes on the lower back panel of the <b>Air Trap</b> with the metal pins on the front of the instrument. |
|---|--|

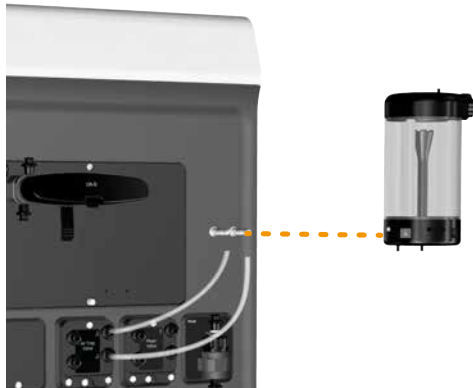

- |   |  |
|---|--|
| 2 | Push the <b>Air Trap</b> firmly on to the pins as far as it will go. |
|---|--|





Step	Action
------	--------

3 Connect the tubing fitted to the **Air Trap Valve** as described as follows.

- Connect the **Air Trap Valve** outlet (marked ) to the **Air Trap** inlet (A, marked )
- Connect the **Air Trap Valve** inlet (marked ) to the **Air Trap** outlet (B, marked )

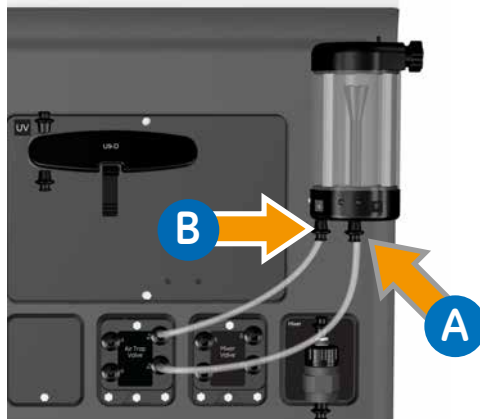

## 4 Installation

### 4.2 Installing the ÄKTA pilot 600 system

#### 4.2.5 Install the pump rinsing system

## 4.2.5 Install the pump rinsing system

### Introduction

The pump rinsing system circulates rinsing solution behind the pump pistons whenever the pumps are running. This helps to lubricate the piston seals and prevent leakage at the seals.

The rinsing solution is recirculated from the rinsing solution bottles, and should be changed regularly (see [Section 7.3.1 Change the pump rinsing solution, on page 166](#)).

### Required materials

The following materials are required:

- About 500 mL 20% ethanol or other suitable rinsing solution

### Install the pump rinsing system

Follow the instructions below to install the pump rinsing tube holder.

Step	Action
------	--------

- |   |   |
|---|---|
| 1 | Align the holes on the back of the pump rinsing bottle holder with the metal pins on the front of the instrument, below the Column Valve. |
|---|---|

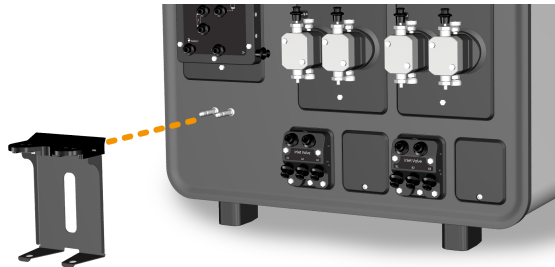

- |   |  |
|---|--|
| 2 | Push the bottle holder firmly on to the pins until it stops. |
|---|--|



- | Step | Action  |
|------|---|
| 3    | Fill each rinsing solution bottle with 250 mL rinsing solution.<br><b>Note:</b><br><i>The recommended rinsing solution is 20% ethanol in water. Other aqueous solutions can also be used.</i> |
| 4    | Push the rinsing solution bottles into the holder, placing the conical bottom of the bottle in the hole in the bottom part of the holder.   |

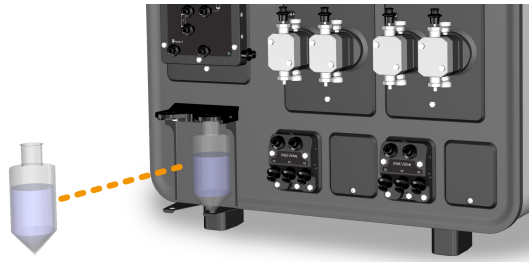

- 5 Fit the rinsing tubing from **Pump A** (Pump A) (two tubes) in the bottle on the left side of the holder and the tubing tubes from **Pump B** (Pump B) (two tubes) in the bottle on the right side of the holder. Arrange the tubes so that both tubes comfortably reach the bottom of the rinsing solution bottles without becoming kinked.

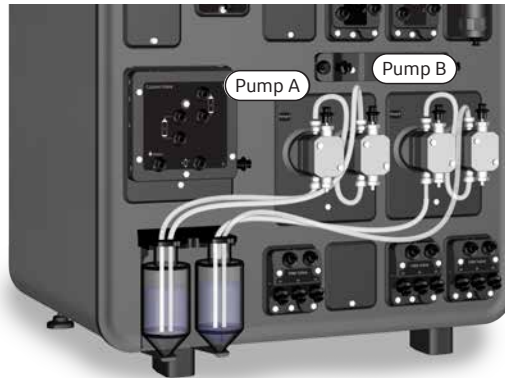

#### NOTICE

Make sure that both tubes from **Pump A** are in the left-hand bottle and both tubes from **Pump B** in the right-hand bottle. Do not mix tubing from **Pump A** and **Pump B**.

## 4 Installation

### 4.2 Installing the ÄKTA pilot 600 system

#### 4.2.6 Fit the pH electrode

## 4.2.6 Fit the pH electrode

### Introduction

The optional pH module is supplied with a dummy electrode fitted in the measuring cell for both ÄKTA pilot 600S and ÄKTA pilot 600R systems. The pH electrode is packaged separately for protection. This section describes how to fit the pH electrode in the pH monitor storage position.

For ÄKTA pilot 600S systems, the pH module must be installed as described in the instructions accompanying the module. For ÄKTA pilot 600R systems, the pH module is installed at the factory.





#### CAUTION

**pH electrode.** Handle the pH electrode with care. The glass tip may break and cause injury.

### Required materials

The following materials are required:

Part	Function	
1	pH electrode in separate box	
2	Locking ring	

Part	Function	
3	Storage cup	
4	Storage solution, about 2 mL (1:1 mixture of pH 4 buffer and 1 M KNO <sub>3</sub> ). This solution must be prepared by the user.	

## Procedure

Follow the instructions below to fit the pH electrode in the storage position in the pH monitor. See [Move the pH electrode to the measuring position, on page 124](#) for instructions on moving the electrode from the storage position to the measuring cell.

Step	Action
------	--------

- |   |   |
|---|---|
| 1 | Place the storage cup in the storage position on the pH module and fill the cup with storage solution up to the mark (approximately 2 mL solution). |
|---|---|



- |   |   |
|---|---|
| 2 | Carefully unpack the pH electrode from its box and locate the locking ring. |
|---|---|

## 4 Installation

### 4.2 Installing the ÄKTA pilot 600 system

#### 4.2.6 Fit the pH electrode

Step	Action
3	Pass the electrode cable through the locking ring so that the ring fits on to the top of the electrode with the threaded opening facing down.



- 4 Carefully remove the protective plastic cover from the pH electrode. Make sure that the electrode is not broken or dry.
- 5 Place the pH electrode in the storage cup. Tighten the locking ring finger-tight.

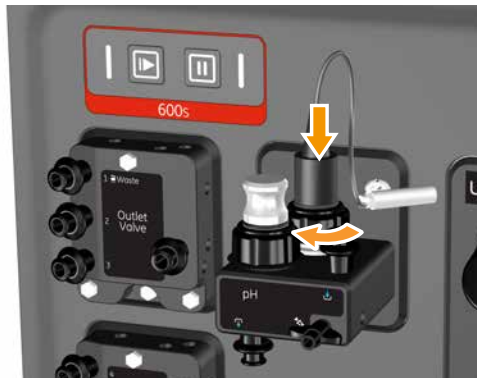

Step	Action
6	Connect the pH electrode cable to the connector on the front of the pH monitor.



Leave the pH electrode in the storage position until it is required for monitoring a run. See [Move the pH electrode to the measuring position, on page 124](#) for instructions on setting up the pH electrode for a run. Replace the electrode in the storage position when the run is completed.

## 4 Installation

### 4.2 Installing the ÄKTA pilot 600 system

#### 4.2.7 Install optional external air sensors

## 4.2.7 Install optional external air sensors

### Introduction

ÄKTA pilot 600 system supports up to 4 external air sensors (numbered 1 to 4) intended for placement in the inlet tubing to detect air entering the system. Action to be taken if air enters the system may vary and is determined by the method. The sensors are identified by number, and in the UNICORN software by their Node ID settings.



#### NOTICE

Do not remove the numbering labels on the air sensors. Do not attempt to change the Node ID setting.

### Installation procedure

Air sensors may be placed on any inlet tubing. Follow the instructions below to install an external air sensor.

Step	Action
------	--------

- |   |  |
|---|--|
| 1 | Connect one port on the air sensor to the required Inlet Valve port using 4.8 mm i.d. tubing and SNAP connectors (A). The air sensor is symmetrical and it does not matter which port is connected to the Inlet Valve. |
|---|--|

**Tip:**

*Allow at least 70 cm tubing between the air sensor and the inlet port at maximum flow rate. Air detected by the sensor may otherwise reach the inlet valve and pump before an Air Alarm is issued by the UNICORN software. Shorter tubing can be used at lower flow rates.*

Connect inlet tubing to the other port on the air sensor (B).

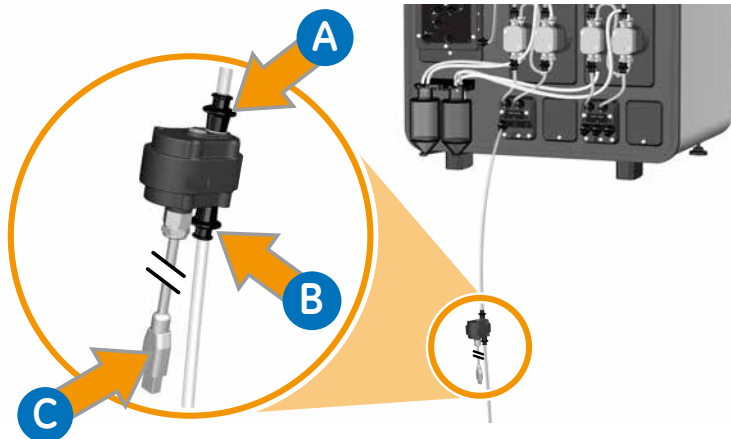



## 4 Installation

### 4.2 Installing the ÄKTA pilot 600 system

#### 4.2.7 Install optional external air sensors

<b>Step</b>	<b>Action</b>
2	Connect the UniNet-9 cable from the air sensor (C) to an unused UniNet-9 port on the back of the instrument.

## 4 Installation

### 4.2 Installing the ÄKTA pilot 600 system

#### 4.2.8 Install the optional steel filter housing

## 4.2.8 Install the optional steel filter housing

### Introduction

This section describes how to install the steel filter housing with filter cassette. A filter cassette in the steel housing is an alternative to the ULTA filter capsule (see [Section 3.5 In-line filters, on page 40](#)).

### Fit filter cassette in housing

Follow the instructions below to fit a filter cassette in the steel housing.

Step	Action
------	--------

- |   |   |
|---|---|
| 1 | Unscrew the filter housing and remove the top part. |
|---|---|



Step	Action
2	Insert a filter cassette into the bayonet fitting in the base of the housing and turn the cassette clockwise to lock it in place (A).

**Note:**

*The filter cassette is not included with the housing, but must be purchased separately (see [Section 3.5 In-line filters, on page 40](#) ).*



**NOTICE**

Avoid touching the filter membrane with any hard or sharp object.

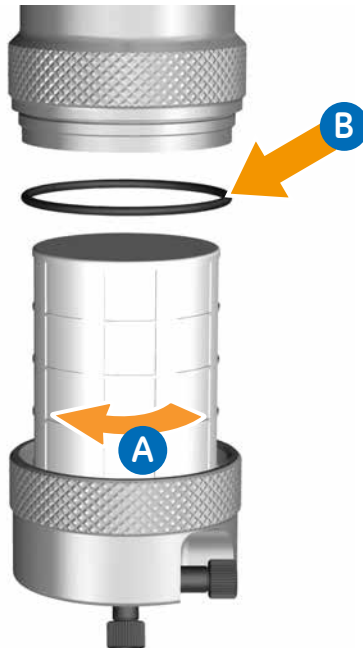

3	Make sure the O-ring in the filter housing is clean and not damaged (B).
---	--

## 4 Installation

### 4.2 Installing the ÄKTA pilot 600 system

#### 4.2.8 Install the optional steel filter housing

Step	Action
------	--------

- |   |  |
|---|--|
| 4 | Screw the two parts of the filter housing together. Tighten by hand. |
|---|--|



- |   |   |
|---|---|
| 5 | Fit the in- and outlet connectors to the filter housing if they are not already fitted. |
|---|---|

## Install the filter on the instrument

Follow the instructions below to install the filter housing with filter cassette.

Step	Action
------	--------

- |   |   |
|---|---|
| 1 | Align the holes on the back panel of the Filter Housing with the metal pins on the front of the UV monitor panel. |
|---|---|

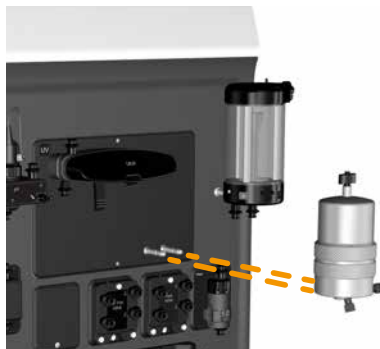



Step	Action
------	--------

- |   |   |
|---|---|
| 2 | Push the Filter Housing firmly on to the pins as far as it will go. |
|---|---|



- |   |  |
|---|--|
| 3 | Connect the filter in the flow path using tubing and SNAP connectors as follows: |
|---|--|

- Connect the **Air Trap** outlet (marked ) to the filter inlet (A).
- Connect the filter outlet to the **Air Trap Valve** inlet (B, marked )

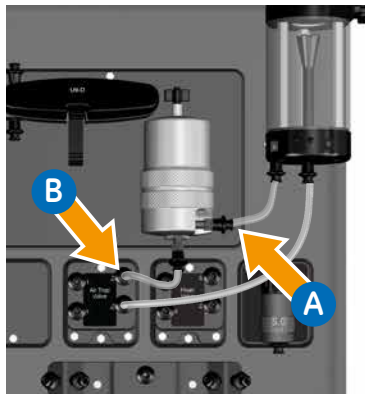

## 4 Installation

### 4.2 Installing the ÄKTA pilot 600 system

#### 4.2.9 Install the optional ULTA filter

## 4.2.9 Install the optional ULTA filter

### Introduction

This section describes how to install the ULTA filter holder and fit the filter capsule in the holder. The ULTA capsule filter is an alternative to filter cassettes in a steel housing (see [Section 3.5 In-line filters, on page 40](#)).



#### WARNING

When ULTA filters are used, the system pressure alarm must be set to a maximum of 5 bar in the UNICORN software **System Settings**.

### Install filter holder

Follow the instructions below to install the holder for ULTA filters.

Step	Action
------	--------

- |   |  |
|---|--|
| 1 | Align the holes on the back panel of the Filter Holder with the metal pins on the front of the UV monitor. |
|---|--|

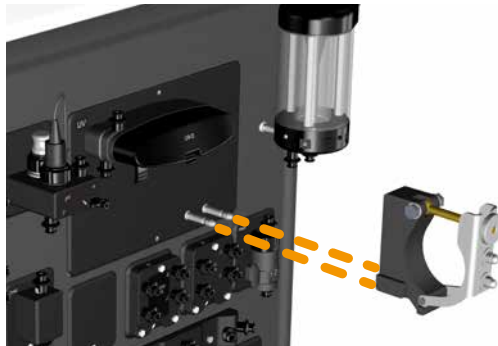

- |   |  |
|---|--|
| 2 | Push the Filter Holder firmly on to the pins as far as it will go. |
|---|--|

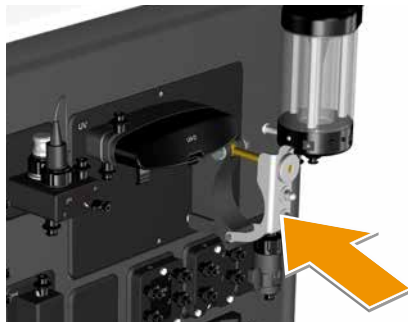

Step	Action
3	Fit the protective guard to the front of the holder as shown using the nuts provided.

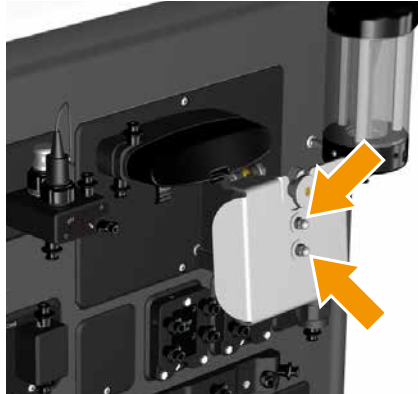

### Install ULTA filter capsule

Follow the instructions below to fit the ULTA filter capsule in the holder and connect the filter in the flow path.

**Note:** *The ULTA filter capsule is not included with the filter holder, and must be purchased separately from Cytiva.*

Step	Action
1	Turn the retaining screw (A) counterclockwise and lift the locking bar to open the filter holder.

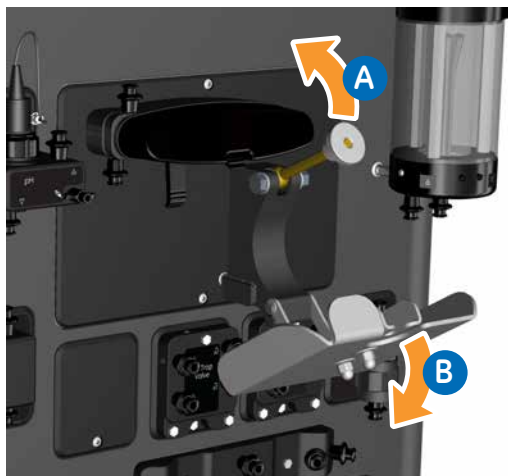

## 4 Installation

### 4.2 Installing the ÄKTA pilot 600 system

#### 4.2.9 Install the optional ULTA filter

Step	Action
2	Fit TC50-to-SNAP connector adapters with seals to the inlet (A) and outlet port (B) on the ULTA filter capsule, using TC50 clamps.

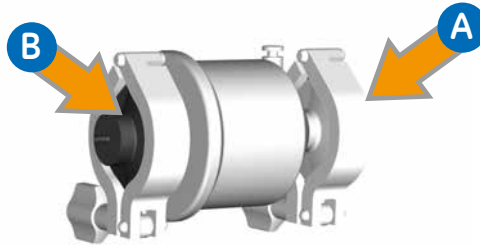

**Note:**

*Make sure that the tightening screws on the TC50 clamps are clear of both the instrument front and the splash guard when the filter holder is closed.*

3	Fit the filter capsule in the filter holder with the air release vent (A) upwards and the flow direction (marked with an arrow on the filter) from right to left (B).
---	---

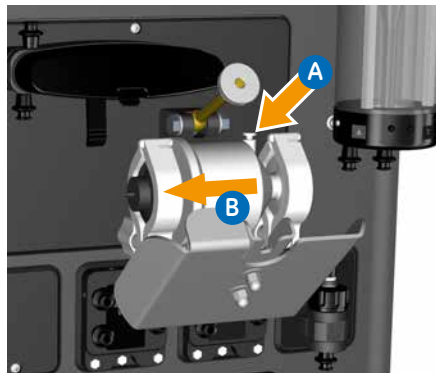

**Note:**

*Make sure that the tightening screws on the TC50 clamps are clear of the instrument front panel and the splash guard. Adjust the rotation of the clamps if necessary.*





Step	Action
------	--------

4	Close the filter holder and tighten the retaining screw fingertight.
---	--



5	Connect the filter in the flow path using tubing lengths and SNAP connectors as follows:
---	--

- Connect the **Air Trap** outlet (marked ) to the filter inlet.
- Connect the filter outlet to the **Air Trap Valve** inlet (marked , **AT**).

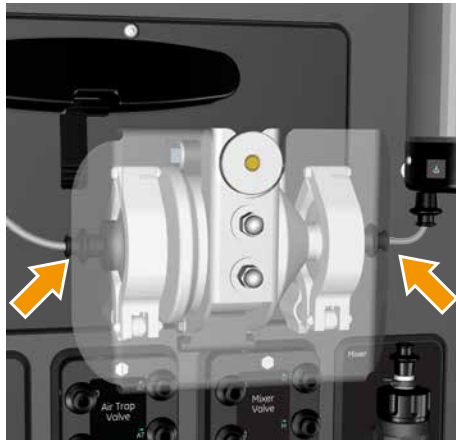

## Set the system pressure alarm

Follow the instructions below to set the system pressure alarm.

## 4 Installation

### 4.2 Installing the ÄKTA pilot 600 system

#### 4.2.9 Install the optional ULTA filter

Step	Action
------	--------

- |   |   |
|---|---|
| 1 | Select <b>System</b> → <b>Settings</b> from the <b>System Control</b> module in UNICORN software to open the <b>System Settings</b> dialog box. |
|---|---|

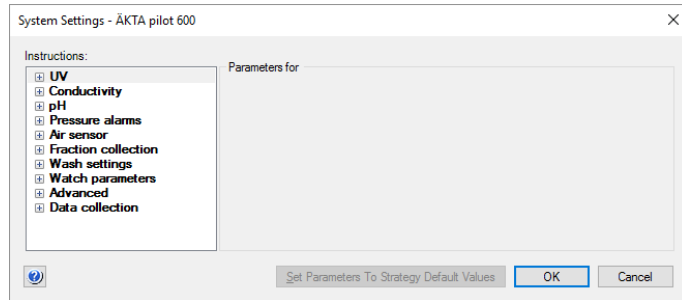

- |   |   |
|---|---|
| 2 | Select <b>Pressure alarms</b> → <b>Alarm system pressure</b> to present the parameters. |
|---|---|

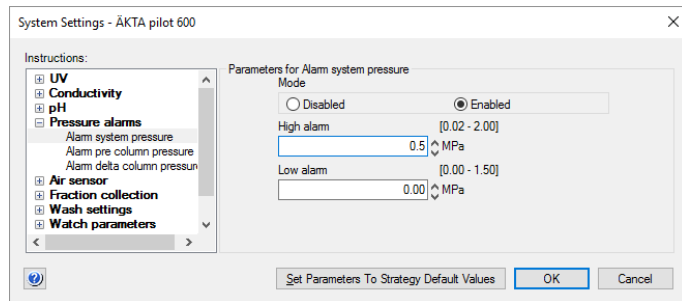

- |   |  |
|---|--|
| 3 | Set <b>High alarm</b> to 0.5 MPa (5 bar).  |
| 4 | Make sure that <b>Enabled</b> is selected. |
| 5 | Click <b>OK</b> .                          |

## 4.2.10 Install and uninstall optional modules

### Introduction

The Standard ÄKTA pilot 600S instrument is delivered with a fixed set of modules installed. Optional modules must be installed and connected by the user.

Modules can be added to the standard system after the instrument and software have been installed. However, it is recommended that optional modules purchased with the system are installed before the system is set up.

**Note:** *Installation of optional modules on a Regulatory system may require re-qualification of the system by Cytiva or an authorized representative.*

**Note:** *The function of a module in the ÄKTA pilot 600 system is determined by the Node ID, a number that identifies the module in the UNICORN software. The Node ID for a module is preset at the factory and should not be changed.*

### Required materials

Installation and uninstallation of optional modules requires the following tools and materials:

- Installation tool (7 mm socket tool)
- Tubing, i.d. 3.2 mm or 4.8 mm
- Tubing cutter
- Tube bender
- SNAP connectors for 3.2 mm or 4.8 mm



#### **CAUTION**

**Sharp tool.** The tubing cutter is very sharp and can cause injuries if it is not handled with care.

### Installing modules in the instrument chassis

Below are general instructions for installing optional valves and monitors in the instrument chassis. More details may be found in the instructions that accompany the module.

<b>Step</b>	<b>Action</b>
-------------	---------------

- |   |  |
|---|--|
| 1 | Disconnect the system in UNICORN software. |
|---|--|

## 4 Installation

### 4.2 Installing the ÄKTA pilot 600 system

#### 4.2.10 Install and uninstall optional modules

Step	Action
------	--------

- |   |  |
|---|--|
| 2 | If the instrument is switched on, switch it off using the <b>ON/OFF</b> button. Press the button briefly, then wait until the button illumination turns off. |
|---|--|



- |   |  |
|---|--|
| 3 | Choose a suitable location for the module on the instrument chassis and unscrew the retaining screw on the module panel. |
|---|--|

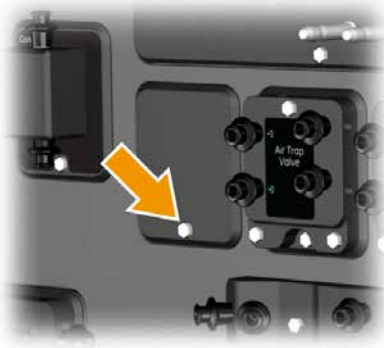

- |   |  |
|---|--|
| 4 | Remove the module panel (A) carefully and disconnect the UniNet-9 connector from the back side of the plate (B). |
|---|--|

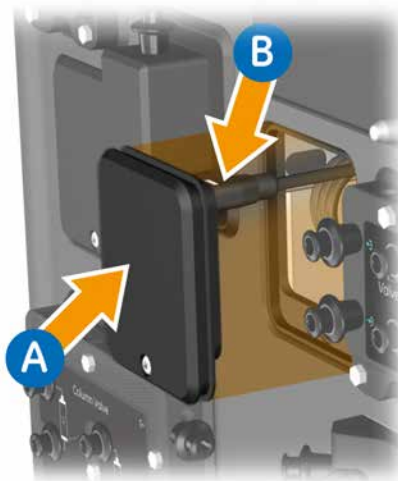

Step	Action
5	Place the connector in the holder so that it does not fall into the instrument.

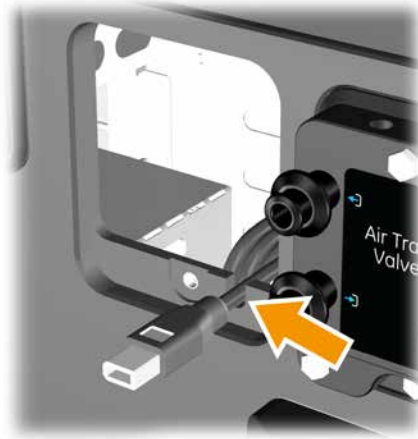

6	Connect the UniNet-9 connector to the module.
---	---

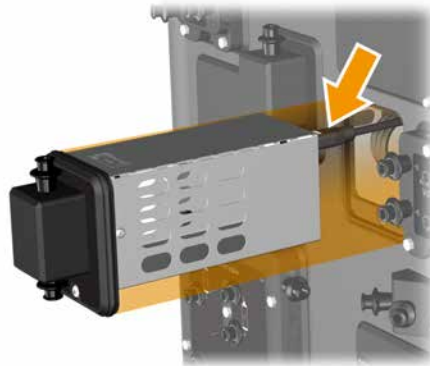

## 4 Installation

### 4.2 Installing the ÄKTA pilot 600 system

#### 4.2.10 Install and uninstall optional modules

Step	Action
7	Fit the module in position on the instrument chassis and tighten the retaining screw.



- 8 Connect the module in the flow path using suitable lengths of tubing as described in the instructions accompanying the module.
- 9 Switch on the instrument.
- 10 Add the module to the system in the UNICORN Administration (see [Configure the system, on page 111](#)).
- 11 Adjust the delay volume if the module is installed downstream of the UV monitor (see [Section 4.7 Delay volumes, on page 115](#)).
- 12 Reconnect the system in UNICORN software (see [Connect to the system, on page 110](#)).

**Tip:** When you add a module to the system in UNICORN software, it is added to the Process Picture in the correct location in the flow path. Check that the tubing connections on the module agree with the Process Picture.

## Installing modules in the Extension box

Below are general instructions for installing optional modules in the Extension box. More details may be found in the instructions that accompany the module.

Step	Action
1	Disconnect the system in UNICORN software.
2	If the instrument is switched on, switch it off using the <b>ON/OFF</b> button.
3	Fit the module in position on the instrument chassis or in the extension box and tighten the retaining screw.

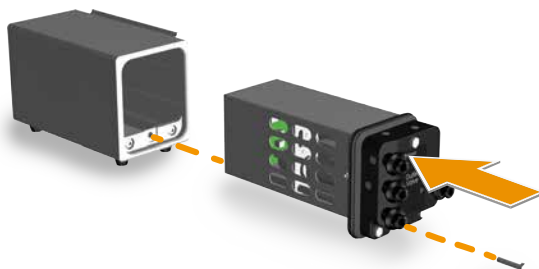

- 4 Connect a UniNet-9 cable (available from Cytiva) to the UniNet-9 port on the back plate of the module (A) and an unused UniNet-9 port on the back of the ÄKTA pilot 600 instrument (B). Secure the cable in the holder on the back of the instrument (C).

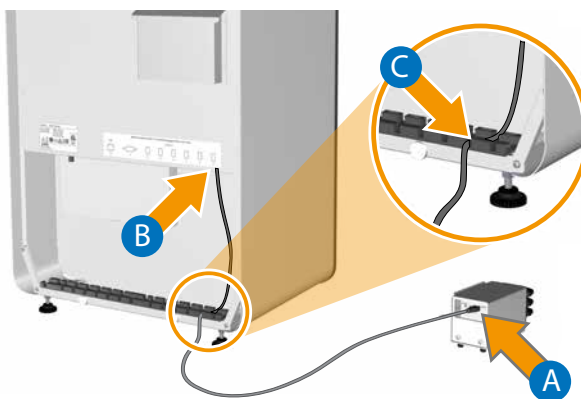

- 5 Connect the module in the flow path using suitable lengths of tubing as described in the instructions accompanying the module.

**Note:**

*Tubing lengths for modules placed downstream of the UV monitor affect the delay volume. See [Section 4.7 Delay volumes, on page 115](#) for details.*

- 6 Switch on the instrument.

## 4 Installation

### 4.2 Installing the ÄKTA pilot 600 system

#### 4.2.10 Install and uninstall optional modules

Step	Action
7	Add the module to the system in the <b>UNICORN Administration</b> (see <a href="#">Configure the system, on page 111</a> ).
8	Adjust the delay volume if the module is installed downstream of the UV monitor (see <a href="#">Section 4.7 Delay volumes, on page 115</a> ).
9	Reconnect the system in UNICORN software (see <a href="#">Connect to the system, on page 110</a> ).

**Tip:** *When you add a module to the system in UNICORN software, it is added to the Process Picture in the correct location in the flow path. Check that the tubing connections on the module agree with the Process Picture.*

### Adding the module in UNICORN software

In order to be used as part of the system, optional modules must be added to the system in UNICORN software. See [Configure the system, on page 111](#) for instructions.

**Note:** *This does not apply to in-line filters. Filters have no functions that can be controlled or monitored from the software.*

### Uninstalling modules

Follow the instructions below to remove a module from the system.

Step	Action
1	Disconnect the system in UNICORN software.
2	If the instrument is switched on, switch it off using the off the <b>ON/OFF</b> button.
3	Disconnect the tubing from the module.
4	Unscrew the retaining screw on the module and remove the module. For modules installed in an extension box, disconnect the UniNet cable from the rear panel of the instrument.



Step	Action
5	<p>For modules installed on the instrument chassis, disconnect the UniNet-9 connector from the back of the module. If the module is not being replaced, connect the UniNet-9 connector to back of the module panel, and replace the module panel on the instrument.</p> <p>If you remove a UniNet cable from the connection panel on the rear of the instrument, replace the cable with a jumper. All UniNet connections must be either used for a module cable or fitted with a jumper.</p> <div data-bbox="435 515 1204 738" style="border: 1px solid black; padding: 10px;"><p data-bbox="602 547 699 576"><b>NOTICE</b></p><p data-bbox="602 589 1174 706">The UniNet-9 cable must be connected to the back of the module panel for all unused module locations. All unused UniNet-9 connectors on the rear of the instrument must be fitted with a jumper.</p></div>
6	Fit tubing to the adjacent modules to restore the flow path.
7	Remove the module from the system in UNICORN Administration (see <a href="#">Configure the system, on page 111</a> ).
8	Switch on the instrument.
9	Reconnect the system in UNICORN software (see <a href="#">Connect to the system, on page 110</a> ).

## 4.3 Connecting the system units

### Introduction

The following connections need to be made:

- Power supply to the computer
- Power supply to the ÄKTA pilot 600 instrument
- Connection between the ÄKTA pilot 600 instrument and the computer
- Connection between the computer and the network (optional)

See [Connectors on the rear panel, on page 29](#) for location of the connectors on the rear panel of the instrument.

### Connect power to the computer

Follow the manufacturer's instructions to connect power to the computer, monitor, and local printer (if used).

### Connect power to the ÄKTA pilot 600 instrument

Follow the instructions to connect power to the ÄKTA pilot 600 instrument.

Step	Action
------	--------

- |   |   |
|---|---|
| 1 | Select the correct power cord to be used. Each instrument is delivered with 2 alternative power cords: <ul style="list-style-type: none"><li>• Power cord with US-plug, 2 m</li><li>• Power cord with EU-plug, 2 m</li></ul> Discard the unused power cord. |
|---|---|

**Note:**

*Contact Cytiva for minimum specifications if you need to use a longer power cord.*

- |   |  |
|---|--|
| 2 | Connect the power cord to the mains input connector on the back of the instrument and to a grounded wall outlet 100 to 240 VAC, 50 to 60 Hz. |
|---|--|

Step	Action
3	Secure the cable in the holder on the back of the instrument.



## Connect the ÄKTA pilot 600 instrument to the computer

Connect a network cable between the **CTRL** connector (network) on the back of the instrument and the computer network port set up for connection to the instrument (see [Network settings, on page 71](#)).

The illustration shows the symbol that identifies the network connector on the instrument.



## Connect the computer to the network

If the computer is to be connected to an external network, use a standard Ethernet connection from the network port that is set up for an external network (see [Network settings, on page 71](#)).

## 4.4 Installing UNICORN software

### Introduction

This section gives an overview of the different UNICORN installation types.

The software should be installed by an assigned UNICORN system administrator. Detailed information about software installation and configuration is available in the UNICORN Administration and Technical Manual.

### Install UNICORN software

Install UNICORN software according to the instructions in the *UNICORN Administration and Technical Manual*.

**Note:** *Installation of the **Column logbook** component of UNICORN is recommended, and is required for correct functioning of Intelligent Packing.*

### Download and install the Instrument Configuration

Follow the instructions below to import the Instrument Configuration into the UNICORN software. The instructions apply to both the initial installation of UNICORN software and to installation of updated Instrument Configuration files.

Step	Action
1	Go to <a href="http://cytiva.com/aktapilot">cytiva.com/aktapilot</a> .
2	Click <b>RELATED DOCUMENTS</b> .
3	Open <b>SOFTWARE</b> .
4	Download the <b>Instrument configuration software</b> from the <b>SOFTWARE</b> section.
5	Unzip the downloaded file to a folder on the local computer.
6	Follow the installation instructions in the unzipped files.

### Define the system in UNICORN software

Define the system in the UNICORN software as described in the *UNICORN Administration and Technical Manual*.

## 4.5 Connecting the ÄKTA pilot 600 instrument to UNICORN software

### Introduction

This section describes how to start the system and connect the ÄKTA pilot 600 instrument to UNICORN software.

### Start the ÄKTA pilot 600 instrument

Follow the instructions below to start the ÄKTA pilot 600 instrument.

Step	Action
------	--------

- |   |                                 |
|---|---------------------------------|
| 1 | Press the <b>ON/OFF</b> button. |
|---|---------------------------------|



- |   |  |
|---|--|
| 2 | When the ÄKTA pilot 600 instrument starts, the following occurs: |
|---|--|

- The **Power/Communication** indicator on the control panel flashes slowly for a few seconds during the self-test procedures.
- After the test, the **Power/Communication** indicator flashes rapidly until connection with UNICORN software is established.



- When the instrument is ready to use, the **Power/Communication** indicator displays a steady light.



### Start UNICORN and log on

Follow the instructions to start UNICORN and log on to the program.

## 4 Installation

### 4.5 Connecting the ÄKTA pilot 600 instrument to UNICORN software

**Note:** Screen illustrations are taken from UNICORN version 7.3. Appearance may differ in other UNICORN versions.

Step	Action
------	--------

1	Double-click the UNICORN icon on the desktop.
---	---

*Result:*

The **Log On** dialog box opens.

2	Enter your username and password. See the UNICORN manual for instructions on creating users. Alternatively, check <b>Use Windows Authentication</b> and log in with your Windows credentials.
---	---



Select the modules you wish to open and click **OK**.

*Result:*

The selected UNICORN modules open.

## Connect to the system

Follow the instructions to connect the instrument to UNICORN.

Step	Action
1	In the <b>System Control</b> module, click the <b>Connect to Systems</b> button.



*Result:*

The **Connect to Systems** dialog box opens.

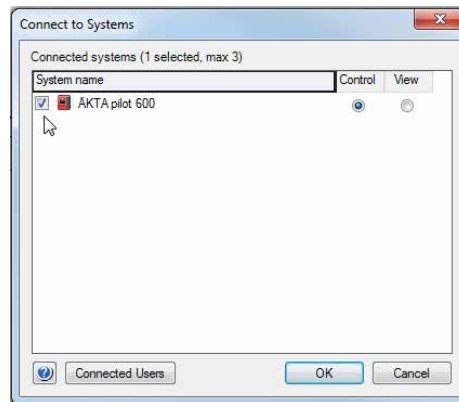

- 2 In the **Connect to Systems** dialog box:
- Select a system check box.
  - Click **Control** for that system.
  - Click **OK**.

*Result:*

When the instrument is ready to use, the **Power/Communication** indicator displays a steady light.

**Note:**

*There may be a short delay before the **Power/Communication** indicator displays a steady light.*

## Configure the system

Modules installed on the instrument must be added to the system in the UNICORN software in order to be recognized by the software.

Brief instructions for configuring the system are given below. Refer to the UNICORN documentation for more details.

## 4 Installation

### 4.5 Connecting the ÄKTA pilot 600 instrument to UNICORN software

Step	Action
------	--------

- 1 Open **System Properties** in the UNICORN **Administration** module.

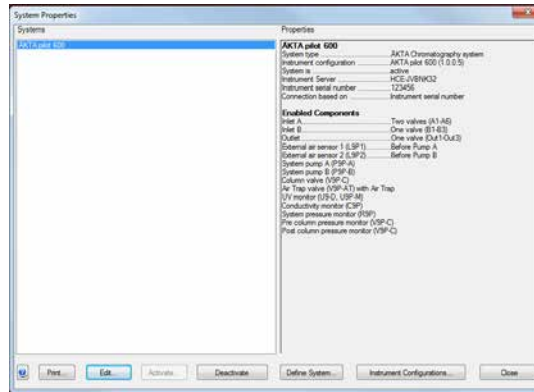

- 2 Select the desired system and click **Edit**.

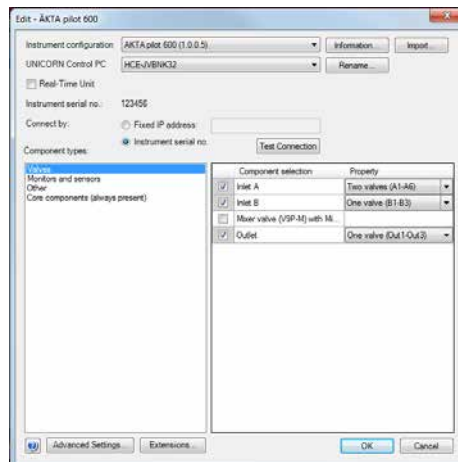



- | Step | Action  |
|------|---|
| 3    | Choose the appropriate <b>Component type</b> and check the required component(s). |

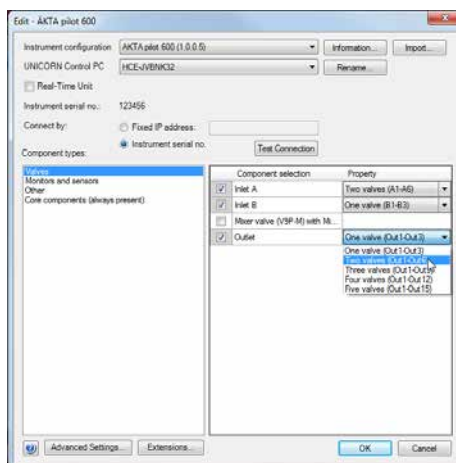

- 4 Click **OK**.  
A warning that the system will be disconnected will appear. Click **Yes**.

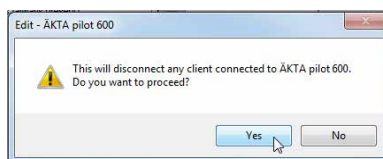

- 5 To reconnect the system, choose **Connect to Systems** from the **Tools** menu in **System Control**.

## 4.6 Performance tests

### **Recommendation**

To check the performance of a newly installed system, selected performance tests may be run. The tests are not a mandatory part of the installation process but can help to establish that the installation has been performed correctly.

Performance test procedures are described in ÄKTA pilot 600 User Manual.

## 4.7 Delay volumes

### Introduction

The delay volume is the volume of the flow path between the detector (normally the UV Monitor) and the outlet, and represents the delay between detection of material and appearance of the material at the outlet. Delay volumes are specified as the volume to the inlet port on each Outlet Valve.

Delay volumes are entered in the UNICORN software so that outlet valve switching is coordinated correctly with detection in the UV monitor.

### Delay volumes in Regulatory systems

For Regulatory systems, delay volumes are specified in the documentation that accompanies the system.

### Delay volumes in Standard systems

As delivered, the Standard system is configured with the UV Monitor outlet directly connected to Outlet Valve 1-3. The delay volume in this configuration is 3.0 mL.

If optional modules are added or tubing length is altered, the delay volume is the total tubing volume plus the internal volume of added modules. Tubing with i.d. 3.2 mm has a volume of 0.08 mL/cm.

### Internal volumes for modules

Internal volumes for optional modules are specified in the installation instructions accompanying the modules.

If delay volumes are calculated for another detector that is placed before the UV Monitor earlier in the flow path than the UV Monitor (for example, the Conductivity Monitor), the internal volume of the UV Monitor should be taken into account. Internal volumes for the UV Monitor with 2 mm and 5 mm optical path length flow cells are given in the table below.

UV Monitor path length	Internal volume
2 mm	0.2 mL
5 mm	0.5 mL

### Example

The table below illustrates how the delay volume is calculated when a pH Monitor is added between the UV Monitor and Outlet Valve 1-3.

Component	Length	Volume
Tubing from UV Monitor to pH Monitor	15 cm	1.2 mL

Component	Length	Volume
pH Monitor internal volume	-	0.77 mL
Tubing from pH Monitor to Outlet Valve 1-3	13 cm	1.04 mL
<b>Delay volume from UV Monitor to Outlet Valve 1-3</b>		<b>3.0 mL</b>

## Enter the delay volume in UNICORN

Follow the instructions below to set the delay volume in UNICORN.

Step	Action
------	--------

- |   |  |
|---|--|
| 1 | Calculate the delay volume from the detector to each outlet valve for all outlet valves installed in the system. |
| 2 | Open <b>System Settings</b> in the <b>System Control</b> module of UNICORN software.                             |

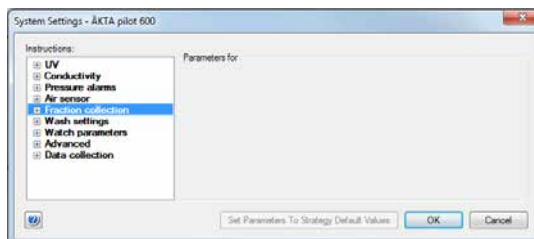

- |   |   |
|---|---|
| 3 | Expand the <b>Fraction collection</b> section and choose <b>Delay volumes</b> . If more than one outlet valve is installed, the dialog includes separate delay volumes for each outlet valve. |
|---|---|

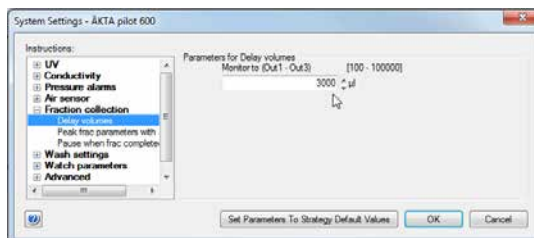

**Note:**

*The dialog shows default values for delay volumes according to standardized positions and tubing lengths for optional modules. Change these values if your calculated delay volumes differ significantly from the default.*

- |   |  |
|---|--|
| 4 | Enter the calculated delay volume for each outlet valve, with a precision of 2 significant digits. |
|---|--|

## 4.8 Moving the ÄKTA pilot 600 system

### Introduction

This section provides instructions for moving the ÄKTA pilot 600 system within and between sites.

For transport over longer distances, pack the instrument securely in a protective box. Use the original packing material if possible.



#### WARNING

**Heavy object.** Use suitable lifting equipment when moving the instrument. Four people are required to lift the system safely. All lifting and moving must be performed in accordance with local regulations.



#### WARNING

When moving the instrument for maintenance or other purposes, disconnect all cables from wall sockets and separate equipment so that the cables do not pull on the instrument or equipment.



#### WARNING

Remove any column with associated tubing, bottles, and inlet, outlet and waste tubing before moving the instrument.

### Preparing to move ÄKTA pilot 600 system

Follow the instructions below to prepare ÄKTA pilot 600 system for moving.

**Note:** *The center of gravity of the instrument is above the center of the instrument and is located towards the instrument front.*



#### CAUTION

**Tipping risk.** Before moving the instrument on a trolley, secure the instrument using straps with a minimum strength of 100 kg.

#### Step

#### Action

- 1 Flush the flow path with water and 20% ethanol.

## 4 Installation

### 4.8 Moving the ÄKTA pilot 600 system

Step	Action
2	Remove the following components: <ul style="list-style-type: none"><li>• Any column with associated tubing</li><li>• Bottles connected to the instrument</li><li>• Inlet, outlet, and waste tubing</li><li>• Tubing and connections to modules installed in a free-standing Extension Box.</li></ul>
3	Empty the bottles for the pump rinsing system.
4	Shut down the computer and instrument (see <a href="#">Shutting down the system, on page 153</a> ).
5	Disconnect the computer from the instrument and remove the computer cable.
6	Disconnect the mains power cable from the instrument.
7	Disconnect any external modules from the UniNet-9 connectors on the rear of the instrument.
8	If the instrument is to be moved on a trolley, secure the instrument on the trolley using a strap to prevent tipping. To avoid damaging instrument components, position the strap between the UV monitor and the outlet valves. Disconnect any tubing that might be damaged by the strap.  <b>Tip:</b> <i>Pass the strap once around the instrument itself and once around the instrument and trolley. Make sure that the instrument cannot tip.</i>

---

Move the instrument carefully, using appropriate lifting and moving equipment.

## Re-installing ÄKTA pilot 600 system at a new location

Follow the instructions below to re-install ÄKTA pilot 600 system at the new location.

Step	Action
1	Check that the new location fulfils the site requirements (see <a href="#">Section 4.1 Site preparation, on page 56</a> ).
2	Place the instrument and computer on a suitable laboratory bench in the new location (see <a href="#">Section 4.1.2 Room requirements, on page 59</a> for space requirements).
3	Use the adjustable feet to compensate for any unevenness in the bench surface.

<b>Step</b>	<b>Action</b>
4	Reconnect the system units (see <a href="#">Section 4.3 Connecting the system units, on page 106</a> ).
5	Place bottles and tubes as required.
6	Prepare the waste tubing and pump rinsing system (see <a href="#">Section 4.2.3 Fit inlet and outlet tubing, on page 72</a> and <a href="#">Section 4.2.5 Install the pump rinsing system, on page 82</a> ).

# 5 Prepare the system for a run

## About this chapter

This chapter gives instructions on how to prepare the ÄKTA pilot 600 system for a run.

## Prerequisites

The instrument must be properly installed in accordance with the instructions in [Chapter 4 Installation, on page 55](#)

Before the user can log on and connect to the instrument, an appropriate User account must have been created in UNICORN.

## In this chapter

Section	See page
5.1 Start the instrument and software	121
5.2 Prepare the flow path	122
5.3 Prepare the pH monitor (optional)	124
5.4 Prime the flow path	130
5.5 Fill the air trap and the filter (optional)	134
5.6 Connect the columns	139



## 5.1 Start the instrument and software

### Start and log on

Follow the instructions in [Section 4.5 Connecting the ÄKTA pilot 600 instrument to UNICORN software, on page 109](#) to start the instrument and software if either component is not started.

### Prepare the system for the chosen type of run

It is important to prepare the system in accordance with the settings in the method to be run. Before preparing the system, verify the settings in the **Method Editor** and make sure that all accessories to be used are available.

5 Prepare the system for a run

5.2 Prepare the flow path

## 5.2 Prepare the flow path

### Introduction

The flow path contains tubing, valves, pumps, mixer, air trap and monitors.

This section describes how to prepare the flow path inclusive mixer (optional) and filter (optional), but except a pH monitor (optional). To prepare a pH monitor, see [Section 5.3 Prepare the pH monitor \(optional\)](#), on page 124.

**Note:** If an optional module is to be installed or uninstalled in the flow path, first read [Section 4.2.10 Install and uninstall optional modules](#), on page 99.

### Flow path overview

The **Process Picture** provides an interactive overview of the flow path. An example is shown in the illustration below. See [Process Picture overview](#), on page 52 for more details of the **Process Picture**.

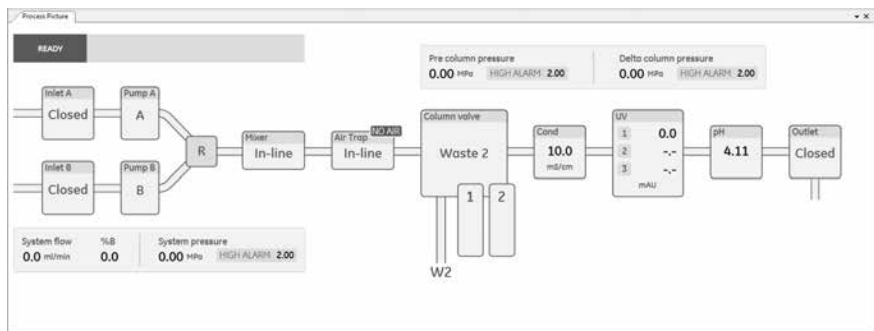

**Note:** The mixer (**Mixer** in the **Process Picture**) and the pH monitor (**pH** in the **Process Picture**) are optional modules.

### Connect required inlets and outlets

Make sure that all inlets and outlets (including waste) that you will use in the method run has suitable connections. For instructions, see [Section 4.2.3 Fit inlet and outlet tubing](#), on page 72.

### Replace a filter (steel housing)

To get high quality result it is recommended to use a new filter for each run. Follow the instructions below to remove an old filter cassette. After removal, install a new filter cassette. For general illustrations and installation instructions, see [Section 4.2.8 Install the optional steel filter housing](#), on page 90.



#### WARNING

**Avoid leakage.** When replacing the filter cassette, make sure that the cassette is correctly fitted.

Step	Action
1	Disconnect the tube ends that connects the steel housing to the flow path.
2	Disconnect the steel housing from the metal pins and carry it to a sink.
3	Open the top valve so that the fluid flows out into the sink (or to a container appropriate for the fluid).
4	Open the steel housing by screwing the top counter-clockwise.
5	Release the bayonet fitting of the old filter cassette by turning the cassette counter-clockwise, and lift out the old filter cassette.
6	Install a new filter cassette, see <a href="#">Section 4.2.8 Install the optional steel filter housing, on page 90</a> .

## Replace a filter (ULTA)

To get high quality result it is recommended to use a new filter for each run. Follow the instructions below to remove an old ULTA filter. After removal, install a new ULTA filter. For general illustrations and installation instructions, see [Section 4.2.9 Install the optional ULTA filter, on page 94](#).



### WARNING

When ULTA filters are used, the system pressure alarm must be set to a maximum of 5 bar in the UNICORN software **System Settings**.

Step	Action
1	Turn the retaining screw counter-clockwise and lift the locking bar to open the filter holder.
2	Disconnect the filter from the flow path by removing the SNAP connectors from the TC-clamps.
3	Carry the filter to a sink.
4	Unscrew and remove TC-clamps and seals so that the fluid flows out into the sink (or to a container appropriate for the fluid).
5	Install a new ULTA filter, see <a href="#">Section 4.2.9 Install the optional ULTA filter, on page 94</a> .

- 5 Prepare the system for a run
- 5.3 Prepare the pH monitor (optional)

## 5.3 Prepare the pH monitor (optional)

### Introduction

The pH monitor is an optional module of ÄKTA pilot 600.

This section describes how to move the pH electrode between storage position and run position, and how to perform a calibration.

### Move the pH electrode to the measuring position



#### CAUTION

**pH electrode.** Handle the pH electrode with care. The glass tip may break and cause injury.

Before starting a run, move the pH electrode from the storage position to the measuring cell of the pH module:

Step	Action
1	Unscrew the locking ring on the dummy electrode (A) and remove the dummy electrode from the measuring cell (B).

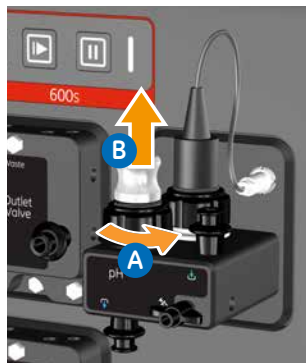

Step	Action
2	Unscrew the locking ring on the pH electrode (A) and lift the pH electrode out of the storage cup (B).

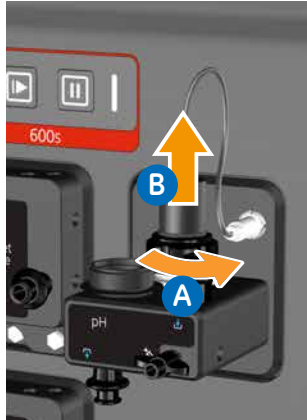

3	Insert the pH electrode into the measuring cell (A). Tighten the locking ring by hand (B).
---	--

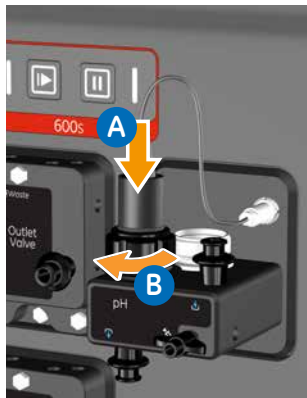

- 5 Prepare the system for a run  
5.3 Prepare the pH monitor (optional)

Step	Action
------	--------

- |   |  |
|---|--|
| 4 | Insert the dummy electrode into the storage cup. Tighten the locking ring by hand. |
|---|--|



- |   |   |
|---|---|
| 5 | Make sure that the pH electrode cable is well connected to the front of the pH monitor. |
|---|---|

## Materials required for the calibration

The recommended procedure uses a 2-point calibration with solutions specified in the table below.

Material	Description
First calibration solution	20 mL of standard buffer with pH 7, equilibrated to ambient temperature.
Second calibration solution	20 mL of standard buffer with pH close to the lowest or highest pH you need to measure, equilibrated to ambient temperature.
Water	2 x 20 mL deionized water.
Syringes	3 syringes with slip tip (one for each solution).

## Calibrate the pH monitor

If the instrument is used daily, calibrate the pH monitor daily. If the instrument is not used daily, calibrate the pH monitor before every run.

Follow the instructions below to perform the calibration.

**Step Action**

- 1 In the **System Control** module, choose **System** → **Calibrate** to open the **Calibration** dialog. Select **pH**, and press **Prepare for calibration**.

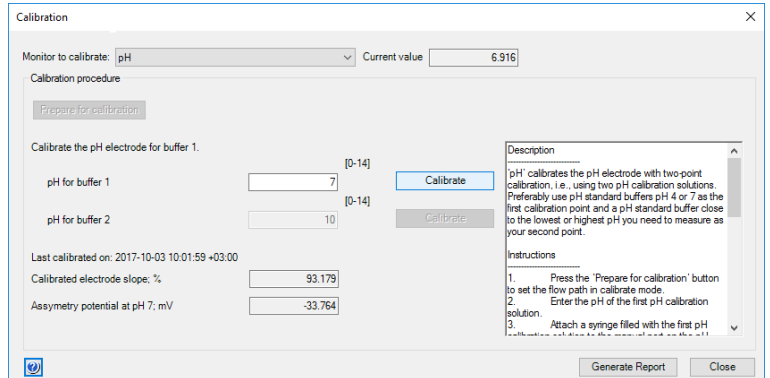

- 2 Enter the pH value of the first calibration solution at **pH for buffer 1**.
- 3 Insert a syringe filled with deionized water to the manual injection port on the pH monitor. Make sure that the syringe is securely attached.



- 5 Prepare the system for a run
- 5.3 Prepare the pH monitor (optional)

Step	Action
------	--------

- |   |  |
|---|--|
| 4 | Open the port (A), inject approximately 20 mL deionized water (B), and close the port. |
|---|--|

**Note:**

*Do not let the port be open without a syringe attached, because air inside the flow cell will impair the calibration.*

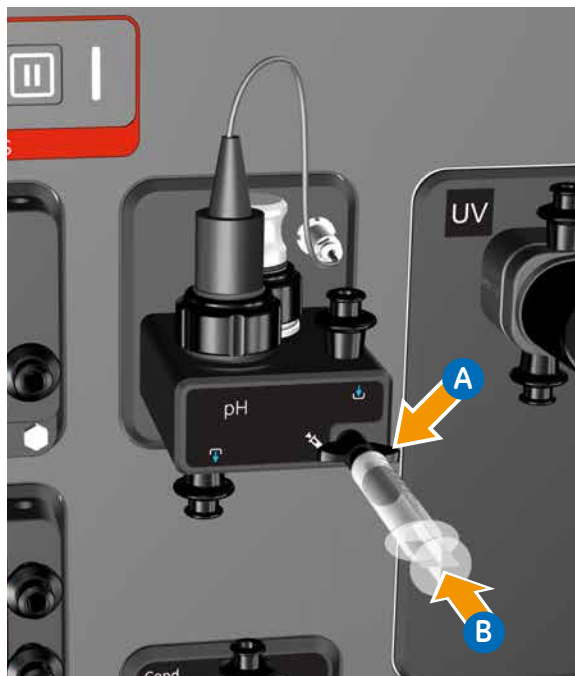

- |   |  |
|---|--|
| 5 | Remove the water syringe, and insert a syringe filled with the first calibration solution.                                 |
| 6 | Open the port, slowly inject approximately 20 mL of the first calibration solution into the flow cell, and close the port. |
| 7 | When the displayed <b>Current value</b> is stable, press <b>Calibrate</b> .  |



- |    |   |
|----|---|
| 8  | Repeat step 3 and 4 to wash the pH electrode.   |
| 9  | When the display changes to <b>pH for buffer 2</b> , enter the pH value of the second calibration solution. |
| 10 | Remove the water syringe, and insert a syringe filled with the second calibration solution.                 |



<b>Step</b>	<b>Action</b>
11	Open the port, slowly inject approximately 20 mL of the second calibration solution into the flow cell, and close the port.
12	When the displayed <b>Current value</b> is stable, press <b>Calibrate</b> .
13	Record the values displayed for the slope and asymmetry potential.

---

**Note:** *After calibration, the slope should be greater than 80% and the asymmetry potential within the range -60 to 60 mV. If the calibration parameters are outside the acceptance limits, clean the pH electrode (see [Cleaning the electrode, on page 163](#)) and repeat the calibration. If the calibration parameters are still outside the acceptance limits, replace the electrode.*

**Tip:** *Test the calibration by measuring a standard buffer.*

## 5 Prepare the system for a run

### 5.4 Prime the flow path

## 5.4 Prime the flow path

### Introduction

The flow path needs to be primed before a run. Priming the flow path can be done using the **Process Picture** or via manual instructions in the **System Control** module or by creating and running a system preparation method.

This section provides instructions for priming the flow path except the air trap and the optional filter, via the **Process Picture** (see example illustration below). To fill the air trap and the optional filter, see [Section 5.5 Fill the air trap and the filter \(optional\), on page 134](#).

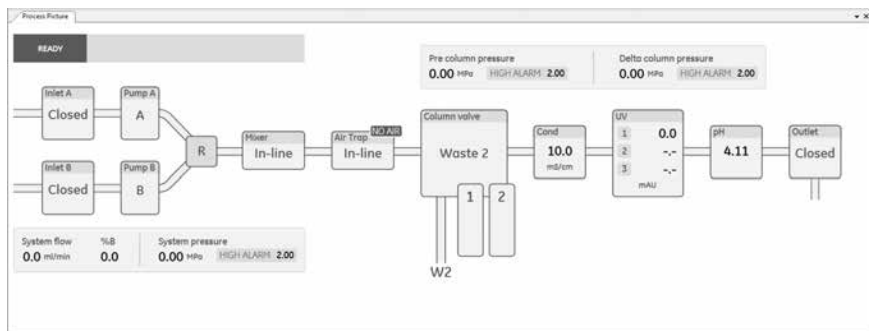

Follow the instructions below in consecutive order.

### Check the pump rinsing solution

Check if the pump rinsing solution is to be changed, see [Section 7.3.1 Change the pump rinsing solution, on page 166](#). If necessary, change to new pump rinsing solution before you prime the inlet tubing.

### Prime the inlet tubing

Follow the instructions below to prime the inlet tubing. Prime all inlets that will be used in the run, using the same solutions that will be used in the run.

**Note:** *Prime the inlet ports in sequence. Make sure the first port used in the method, is primed last using the method starting buffer.*

Step	Action
------	--------

- |   |  |
|---|--|
| 1 | <p>Click <b>Inlet B</b> to open the <b>Inlet B</b> dialog box, and select an inlet port.</p> <p>If the flow path does not change color because the run is paused or stopped, click <b>Continue</b> in the <b>System Control</b> toolbar.</p> |
|---|--|

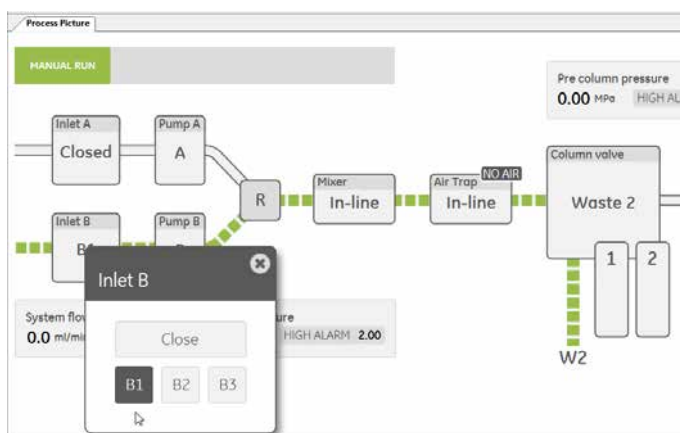
**Result:**



The flow path changes from gray to dashed green, indicating an open flow path from **Inlet B** to **Waste 2**, but no flow.

- |   |  |
|---|--|
| 2 | If the system has a mixer, click <b>Mixer</b> and set it to <b>By-pass</b> .   |
| 3 | Click <b>Air Trap</b> and set it to <b>By-pass</b> .   |
| 4 | <p>Start pump B at a high flow rate:</p> <ol style="list-style-type: none"> <li>Click <b>Pump B</b> to open the <b>System pumps</b> dialog box.</li> <li>Set <b>Conc % B</b> to <b>100%</b>, and click <b>Set</b> below.</li> <li>Set <b>System flow</b> to 600 mL/min, click <b>Set</b> below and be prepared to do the following steps approximately 15 seconds after each other.</li> </ol> |

**Result:**

The flow path changes to solid green, indicating open flow path and flow from **Inlet B** to **Waste 2**.

**Tip:**

To take a short break during this and the following steps without flushing the solution, click the **Pause** button  in the **System Control** toolbar. To continue, click the **Continue** button .

- |   |  |
|---|--|
| 5 | After approximately 15 seconds, click <b>Inlet B</b> and select the next inlet B port to be primed. Repeat this step until all inlet B ports that will be used have been primed. |
|---|--|

## 5 Prepare the system for a run



### 5.4 Prime the flow path

Step	Action
6	<p>Approximately 15 seconds after the last B port is primed, redirect the flow to use pump A:</p> <ol style="list-style-type: none"><li>Click <b>Inlet A</b> and select an inlet port.</li><li>Click <b>Pump A</b> to open the <b>System pumps</b> dialog box.</li><li>Set <b>Conc % B</b> to <b>0%</b>, and click <b>Set</b> below.</li></ol> <p><i>Result:</i></p> <p>Pump A starts, pump B stops, and the solid green path now indicates open flow path and flow from <b>Inlet A</b> to <b>Waste 2</b>.</p>
7	<p>After approximately 15 seconds, click <b>Inlet A</b> and select the next inlet A port to be primed. Repeat this step until all inlet A ports that will be used have been primed.</p>
8	<p>Click the <b>End</b> button  in the <b>System Control</b> toolbar.</p>
9	<p>If the pump rinse solution has been changed recently, make sure that the rinse solution tubing now is filled with solution.</p>

## Prime the system flow path

Follow the instructions below to prime the system flow path using the starting buffer from inlet A.

Step	Action
1	<p>Open a flow path straight through the whole system using column by-pass number 1:</p> <ol style="list-style-type: none"><li>Click <b>Inlet A</b> and select the starting buffer inlet port.</li><li>If the system has a mixer, click <b>Mixer</b> and set it to <b>By-pass</b>.</li><li>Click <b>Air Trap</b> and set it to <b>By-pass</b>.</li><li>Click <b>Column valve</b>, select <b>By-pass 1</b> from the drop-down list, and click <b>Set position</b>.</li><li>Click <b>Outlet</b> and select <b>Waste/Out 1</b>.</li></ol> <p><i>Result:</i></p> <p>The flow path changes to dashed green, indicating an open flow path from <b>Inlet A</b> to <b>Outlet</b>, but no flow.</p>

Step	Action
2	<p>Start pump A at a high flow rate:</p> <ol style="list-style-type: none"><li>Click <b>Pump A</b> to open the <b>System pumps</b> dialog box.</li><li>Set <b>Conc % B</b> to <b>0%</b>, and click <b>Set</b> below.</li><li>Set <b>System Flow</b> to 600 mL/min, click <b>Set</b> below and be prepared to do the following steps approximately 30 seconds after each other.</li></ol> <p><i>Result:</i></p> <p>The flow path changes to solid green, indicating an open flow path and flow.</p> <p><b>Tip:</b></p> <p>To take a short break during this and following steps without flushing solution, click the <b>Pause</b> button  in the <b>System Control</b> toolbar. To continue, click the <b>Continue</b> button .</p>
3	<p>After approximately 30 seconds, redirect the flow through the mixer and through column by-pass number 2:</p> <ol style="list-style-type: none"><li>If the system has a mixer, click <b>Mixer</b> and set it to <b>In-line</b>.</li><li>Click <b>Column valve</b>, select <b>By-pass 2</b> from the drop-down list, and click <b>Set position</b>.</li></ol>
4	<p>After approximately 30 seconds, click <b>Outlet</b> and select the next outlet port to be primed. Repeat this step until all outlet ports that will be used have been primed.</p>
5	<p>Click the <b>End</b> button  in the <b>System Control</b> toolbar.</p>

- 5 Prepare the system for a run
- 5.5 Fill the air trap and the filter (optional)

## 5.5 Fill the air trap and the filter (optional)

### Introduction

The air trap tubing should be washed and the air trap should be filled with a suitable solution even if the air trap will not be in-line during the run. If a filter will be used, the filter must be filled before the run.

Follow the instructions below in consecutive order.

**Note:** *If cleaning of the air trap is necessary, use a **System CIP** method to clean the air trap before following the instructions below.*

### Air trap fill levels

In ÄKTA pilot 600, the fill level in the air trap is related to the flow rate. It also depends on type of the run to be used for example, isocratic or gradient run.

The table below describes the level required for the different run conditions.

Run condition	Fill level
Isocratic run	Full
Gradient run, flow rate > 100 mL/min	Full
Gradient run, flow rate < 100 mL/min	Fill only 1 cm from the bottom. The level will rise during the run, when the system pressure increases.

### Wash the air trap tubing and fill the air trap

Follow the instructions below to wash the air trap tubing and fill the air trap.

Step	Action
1	Click <b>Air Trap</b> in the <b>Process Picture</b> to open the <b>Air Trap valve</b> dialog box.
2	Set parameters in the dialog box: <ul style="list-style-type: none"> <li>• Click <b>In-line</b> to set the air trap to in-line.</li> <li>• Below <b>Fill Air Trap</b>, select inlet port, A, B or both. If B is selected, also set <b>Conc % B</b>.</li> <li>• Set <b>Pre/Post wash</b> to <b>On</b> to wash the air trap tubing.</li> </ul>

Step	Action
------	--------

3	Click <b>Start fill</b> .
---	---------------------------

*Result:*

The following dialog box opens.

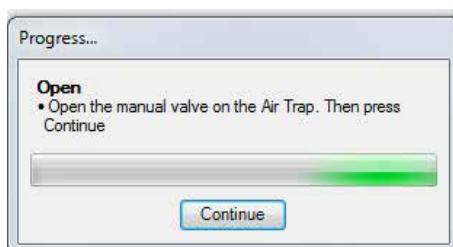

4	Open the manual valve on the air trap.
---	--



**Tip:**

*Fit a tube from the top SNAP connector to waste, to avoid spillage when the air trap is completely filled.*

- 5 Prepare the system for a run
- 5.5 Fill the air trap and the filter (optional)

Step	Action
------	--------

- |   |   |
|---|---|
| 5 | Press the <b>Continue</b> button  on the instrument control panel, keep an eye on the increasing amount of liquid in the air trap, and be prepared to press <b>Continue</b> again as described in the next step. |
|---|---|

*Result:*

First the pre wash of the tubing starts, and the **PRE WASH** dialog box opens. When the pre wash is finished, the filling of the air trap starts, and the **FILL** dialog box opens. During the pre wash, it is possible to abort the filling by clicking **Abort** in the **PRE WASH** dialog box.

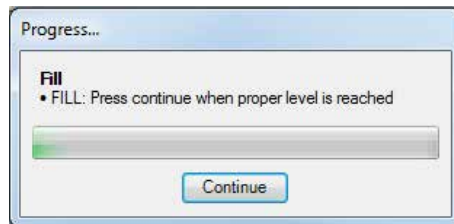
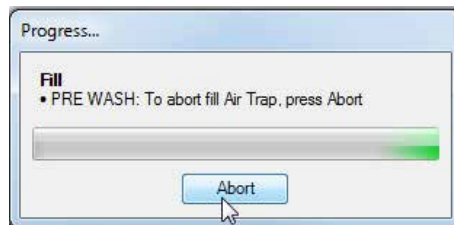



- |   |   |
|---|---|
| 6 | When the appropriate level is reached, stop the filling by pressing the <b>Continue</b> button  again. |
|---|---|

*Result:*

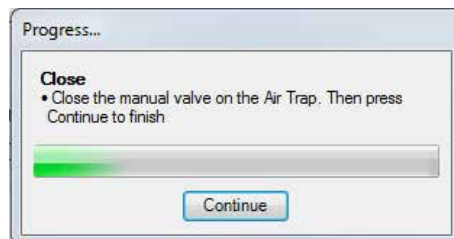
The filling stops, and the following dialog box opens.



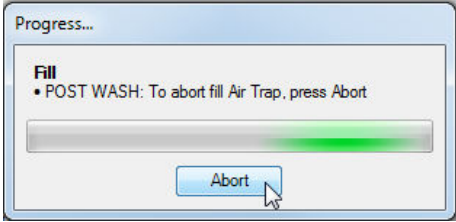

Step	Action
7	<p>Close the manual valve on the air trap, and click <b>Continue</b>.</p> <p><i>Result:</i></p> <p>The post wash starts, and the following dialog box opens. During the post wash of the tubing, it is possible to abort the filling by clicking <b>Abort</b> in the <b>POSTWASH</b> dialog box.</p> 
8	<p>Wait until the post wash is finished, then click the <b>End</b> button  in the <b>System Control</b> toolbar.</p>

## Fill the optional filter

Before starting a run, air should be removed from the filter. The same procedure as when filling the air trap can be used to fill the filter with liquid.



Follow the instructions below to fill the filter.

Step	Action
1	Click <b>Air Trap</b> in the <b>Process Picture</b> to open the <b>Air Trap valve</b> dialog box.
2	<p>Set parameters in the dialog box:</p> <ul style="list-style-type: none"><li>• Select <b>In-line</b>, same as when filling the air trap.</li><li>• Select inlet ports, same as when filling the air trap.</li><li>• Set <b>Pre/Post wash</b> to <b>Off</b>.</li></ul>
3	<p>Click <b>Start fill</b>.</p> <p><i>Result:</i></p> <p>The <b>Open</b> dialog box opens.</p>

- 5 Prepare the system for a run
- 5.5 Fill the air trap and the filter (optional)

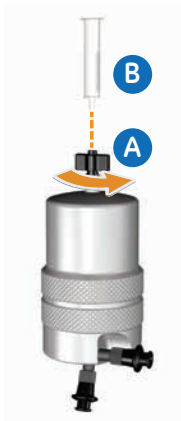
Step	Action
4	<p>Open the air vent valve on the filter (A) and insert a syringe (B) without the plunger.</p> <p>The illustration shows the steel filter housing, the ULTA filter has a similar air vent valve.</p>



- 5 Press the **Continue** button  on the instrument control panel, keep an eye on the syringe, and be prepared to do the next step.  
*Result:*  
The filling of the filter starts, and the **FILL** dialog box opens.
- 6 When the syringe start to fill and no bubbles can be seen, stop the filling by pressing the **Continue** button  again.  
*Result:*  
The filling stops, and the **Close** dialog box opens.
- 7 Close the air vent valve on the filter, and click **Continue**.
- 8 Run a flow with a high flow rate to remove remaining air.
- 9 Click the **End** button  in the **System Control** toolbar.

## 5.6 Connect the columns

### Introduction

One or two packed columns can be connected to the ÄKTA pilot 600 instrument. The columns can be run separately or in series.

This section describes how to connect one packed column to position **1**, using the **Process Picture** to control the flow path.

### Before connecting a column

Do the following before connecting a column to the ÄKTA pilot 600 instrument:

- Make sure you have read the instruction for the selected column.
- Make sure you have appropriate tubing and unions. There are more unions available from Cytiva than the unions enclosed at delivery.
- Make sure the flow path is primed with a suitable buffer, see [Section 5.4 Prime the flow path, on page 130](#).
- Set appropriate maximum pressure limits for the selected column, see below.

### Set pressure limits

When using pre-defined methods in UNICORN, the pressure limits are automatically set for the selected column. In manual runs, pre and delta column pressure limits have to be set manually. Follow the instructions below to set the limits using the **Process Picture**.

**Tip:** To find correct values, see the instructions for the selected column.

Pre column pressure 0.00 MPa HIGH ALARM 2.00	Delta column pressure 0.00 MPa HIGH ALARM 2.00
---	---



#### WARNING

Before connecting a column, read the instructions for use of the column.

Step	Action
1	Set the pre column pressure: <ol style="list-style-type: none"> <li>In the <b>Pre column pressure</b> panel, click <b>HIGH ALARM</b>.</li> <li>In the pop-up window, set the <b>High limit</b> value for the selected column.</li> <li>Click <b>Set</b>.</li> </ol>

## 5 Prepare the system for a run

### 5.6 Connect the columns

Step	Action
2	Set the delta column pressure: <ol style="list-style-type: none"><li>In the <b>Delta column pressure</b> panel, click <b>HIGH ALARM</b>.</li><li>In the pop-up window, set the <b>High limit</b> value for the selected column.</li><li>Click <b>Set</b>.</li></ol>
3	Make sure that the alarm setting is <b>ON</b> .

## Connect the column

Follow the instructions below to connect a packed column to position **1**.

Step	Action
1	Connect the column as indicated on the <b>Column valve</b> panel.

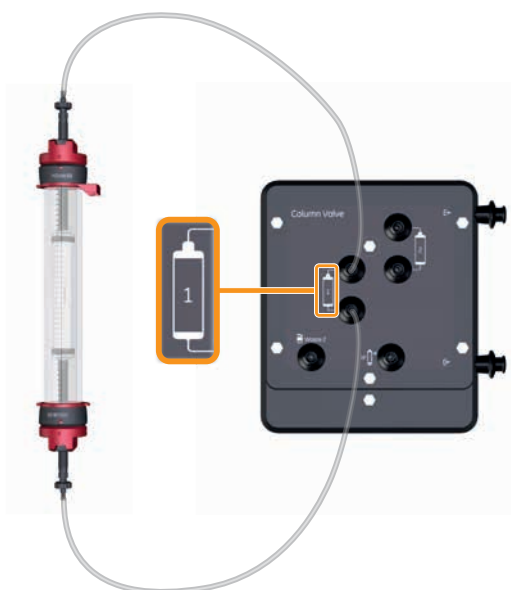

### Tip:

*If the column tubing has smaller diameter than the instrument tubing, position the unions near the instrument.*

- 2 Start a low flow to the **Waste 2** port:
  1. Click **Inlet A** and select the inlet of the buffer (usually **A1**).
  2. Click **Pump A**.
  3. Set **Conc % B** to 0% and **System Flow** rate to 5 mL/min.

Step	Action
------	--------

3	Disconnect the column top tubing.
---	-----------------------------------



4	Fill the disconnected tubing:
---	-------------------------------

- a. Click **Outlet** and select **Waste/Out 1**, to open the flow path.
- b. Click **Column valve**, select **Column 1 downflow** and click **Set position**, to redirect the flow.

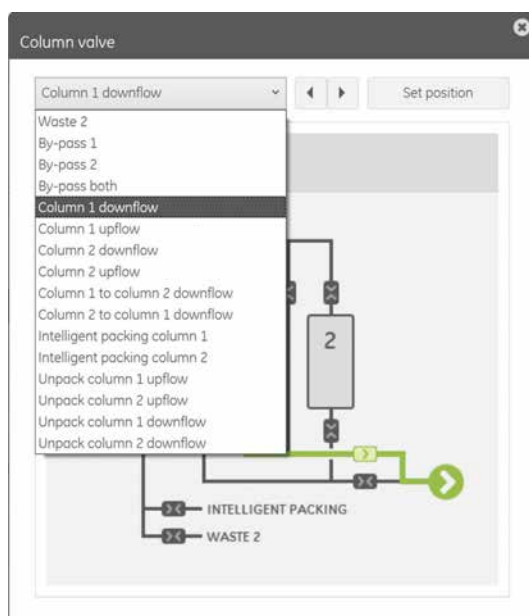

## 5 Prepare the system for a run

### 5.6 Connect the columns

<b>Step</b>	<b>Action</b>
-------------	---------------

- |   |   |
|---|---|
| 5 | When the disconnected tubing is filled, reconnect it drop-to-drop to the top of the column. Make sure that there is no air in the connection. |
|---|---|



- |   |  |
|---|--|
| 6 | When the tubing at the bottom of the column is filled, click the <b>End</b> button  in the <b>System Control</b> toolbar. |
|---|--|

# 6 Perform a run

## About this chapter

This chapter gives instructions on how to safely perform a run using the ÄKTA pilot 600 system.

## In this chapter

<b>Section</b>	<b>See page</b>
6.1 Before you start	144
6.2 Manual operations	146
6.3 Sample application	147
6.4 Start a method run	150
6.5 Monitor the run	151
6.6 Procedures after the run	152

## 6.1 Before you start

### Introduction

It is necessary to read and understand the information in this section and to perform the final checks before start.

### Safety precautions



#### WARNING

**High pressure.** The flow rate may under no circumstances exceed the specified column maximum flow rate. High flows might affect the packed resin, causing the pressure to exceed the specified column maximum pressure.



#### WARNING

To avoid exposing system components to excessive pressure, make sure that the system pressure limit is set at or below the specified maximum pressure for the component with the lowest pressure limit (including in-line filters, which often have lower pressure tolerance than other system components).



#### WARNING

**Overpressure.** Never block the outlet tubing with, for instance, stop plugs, since this will create overpressure and might result in injury.



#### CAUTION

The flow path may remain pressurized while a run is paused. Do not loosen any connections.



#### CAUTION

Secure all outlet tubing carefully so that it remains in the container even when high flow rates cause vibrations in the tubing.

### Final checks before start

Before starting a run, make sure that the system is prepared according to [Chapter 5 Prepare the system for a run, on page 120](#), and verify the following:



- The system pressure alarm limit is adjusted to the component before the column with the lowest pressure limit. (Use **Process Picture** → **System pressure** → **HIGH ALARM**.)
- The system is prepared according to the settings in the method to be run.
- A suitable column for the application is selected and properly connected to the Column valve, and the pressure limit is set to a value appropriate for the column.
- The tubing from each waste outlet is inserted and secured in appropriate waste containers considering container size and placement.
- The tubing from each inlet is inserted and secured in the corresponding buffer containers.
- The tubing from the inlet required for sample application is inserted and secured in the sample container.
- The tubing from each outlet is rinsed and secured in appropriate collection containers.
- The pump rinsing system is installed and filled with rinsing solution, see [Section 4.2.5 Install the pump rinsing system, on page 82](#).
- The tubing is not kinked and the flow path is primed and free from leakage.

## 6.2 Manual operations

### Introduction

Manual operations are performed from the **System Control** module in UNICORN.

**Note:** Any manual interactions performed during a manual or method run will be logged and saved in the run result.

### Manual instructions dialog box

All manual instructions are available from the **Manual instructions** dialog box. Select **System Control** → **Manual** → **Execute Manual Instructions** to open the dialog box.

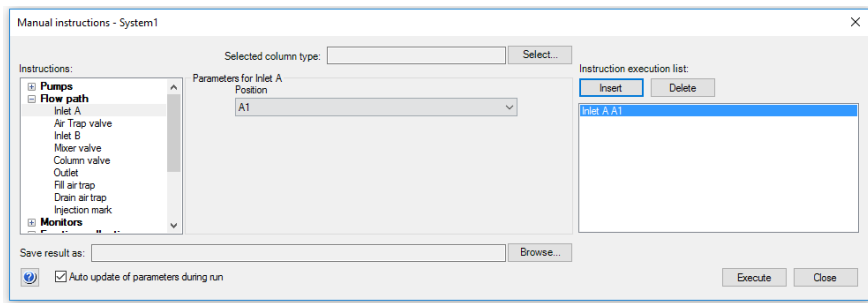

See also the UNICORN System Control Manual, for access see [UNICORN documentation, on page 9](#).

### Process Picture

Interactions with the system can be performed directly from the **Process Picture** by clicking on the icons in the flow path.

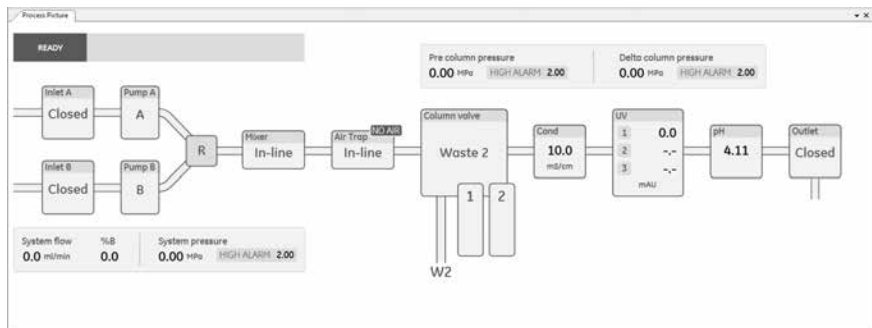

See also [Process Picture overview, on page 52](#), and [Chapter 5 Prepare the system for a run, on page 120](#).

## 6.3 Sample application

### Introduction

This section describes how to select sample application technique and parameter values in a UNICORN method.

See the *UNICORN Method Editor Manual* for information about how to create and edit a method.

For more information regarding the different sample application techniques, refer to *ÄKTA pilot 600 User Manual* and Superloop instructions.

### Sample injection methods

Sample application in ÄKTA pilot 600 is performed using the system pump. The following table describes two options.

Option	When?	Description
<b>Inject sample directly onto column</b> Inject sample directly onto column	Recommended for larger sample volumes >50 mL.	The sample is pumped directly onto the column from one of the A inlets using system pump A.
<b>Inject Sample from a Superloop, manual load</b> Inject Sample from a Superloop, manual load	Recommended for 10 to 150 mL.	A Superloop (sold separately) is manually filled with sample and connected to one of the two column positions. The sample is injected onto the column by directing the system flow via the Superloop.

### Inject sample directly onto column

Follow the instructions below to modify the sample application phase in the method, to inject a fixed volume directly onto the column.

## 6 Perform a run

### 6.3 Sample application

Step	Action
------	--------

- |   |  |
|---|--|
| 1 | In the <b>Sample Application</b> phase, open the <b>Phase Properties</b> tab.  |
| 2 | Select <b>Inject sample directly onto column</b> (Inject sample directly onto column).   |
| 3 | Select <b>Sample inlet</b> (A inlet).  |
| 4 | Make sure <b>Inject fixed sample volume</b> is selected, and enter the sample volume.  |
| 5 | Check <b>Finalize sample injection</b> , and enter the chase volume.<br>The chase function uses buffer ( <b>A inlet</b> as set in <b>Method Settings</b> ) to assure all sample in the flow path is transported to the column. The default value for a Standard system is 50 mL. If the Air Trap is used, larger volume is needed. |
| 6 | If needed, change the <b>Fractionation start position</b> . <b>Out 2</b> is selected by default.   |
| 7 | Save the method.   |

**Note:** Avoid introducing air into the inlet sample tubing before starting the run.

## Inject sample from Superloop, manual load

Follow the instructions below to modify the sample application phase in the method, to use a Superloop.

Step	Action
1	In the <b>Sample Application</b> phase, open the <b>Phase Properties</b> tab.
2	Select <b>Inject sample from Superloop, manual load</b> (Inject sample from Superloop, manual load).
3	At <b>Loop position</b> , select the position of the Superloop.
4	At <b>Empty loop with</b> , enter the sample volume to apply. When the Superloop is filled with exact sample volume it is recommended to add 10 ml to make sure the Superloop is completely emptied. The additional volume will consist of buffer from the flow path.
5	If needed, change the <b>Fractionation start position</b> . <b>Out 2</b> is selected by default.
6	Save the method.

## 6.4 Start a method run

### Introduction

This section describes how to start a method run in the UNICORN **System Control** module.

### Method run

Follow the instructions below to open and start a method run in UNICORN.

**Note:** For creating a method refer to *UNICORN Method Manual*.

**Step**      **Action**

---

1            In the **System Control** module, click the **Open Method Navigator** icon .

2            Select the required method.

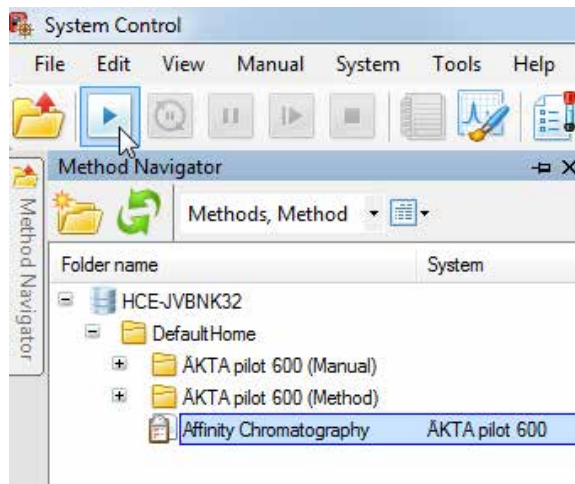

3            Click **Run**  on the toolbar.

*Result:*

The **Start Protocol** dialog box opens.

4            Step through the displayed pages in the **Start Protocol**, enter the required information, and click **Next**.

5            Click **Start**.

*Result:*

The method starts.

---

## 6.5 Monitor the run

### Introduction

The run is monitored in the UNICORN **System Control** module as follows:

- The run progress is monitored in the **Chromatogram** pane.
- The current flow path and current numerical data from monitors are shown in the **Process Picture**.
- All registered actions during the run are displayed in the **Run Log** pane.

For details on the **System Control** interface, see [Section 3.8.2 The System Control module, on page 50](#).





### Interact with the run

You can interact with the run by changing the run parameters directly in the **Process Picture** or in the **Manual instructions** dialog box. When parameters are changed, the displayed values are updated.

**Note:** *Changing parameters during a run needs to be done with care, since it may have a big impact on the run.*

### Interrupt a method

At the end of a method the run stops automatically. All pumps stop and an acoustic end signal sounds, and **End** is displayed in the **Run Log**.

To interrupt a method or a manual run, use the **Hold** , **Pause** , or **End**  buttons in the **System Control** toolbar. A held or paused method run can be resumed by clicking the **Continue**  button. For details, see [System Control toolbar buttons, on page 51](#).

## 6.6 Procedures after the run

### Introduction

After the run, the instrument and column should be cleaned to prevent bacterial growth, sample contamination in the next run, and column clogging.

This section describes how to clean or sanitize the instrument, prepare the instrument for storage and how to shut down the system.

**Note:** For column CIP and column storage refer to the column instructions.

### Cleaning the instrument flow path

To clean the instrument flow path, run the **System CIP** method or the **System Sanitization** method.

The following table gives a brief description of the two methods.

Method	Description
<b>System CIP</b> (Cleaning-In-Place)	A pre-defined method used to clean selected parts of the flow path after a run.
<b>System Sanitization</b>	A pre-defined method used to clean the entire flow path and all inlets in a well-defined way. The method includes manual steps and uses 1 M NaOH, 0.9% NaCl, 20% EtOH, and distilled water.

For further instructions, see [Section 7.2 Cleaning procedures, on page 158](#).

### Leaving the instrument for a few days

If the instrument is not going to be used for a few days, follow the instructions below.

Step	Action
------	--------

- |   |  |
|---|--|
| 1 | If you have used the pH electrode: <ol style="list-style-type: none"><li>Remove the electrode from the measuring position.</li><li>Rinse the pH electrode with water.</li><li>Shift the pH electrode with the dummy electrode.</li></ol> |
|---|--|

**Note:**

Make sure you have a 1:1 mixture of pH 4 buffer and 1 M KNO<sub>3</sub> in the storage holder.

**Tip:**

If needed, see text and images in [Section 5.3 Prepare the pH monitor \(optional\), on page 124](#).



Step	Action
2	Change the pump rinsing solution, use 20% ethanol. See <a href="#">Section 7.3.1 Change the pump rinsing solution, on page 166</a> .
3	Clean the system by running the <b>System CIP</b> or the <b>System Sanitization</b> method.
4	Fill the system with 20% ethanol.

For further instructions on cleaning and maintenance, see [Chapter 7 Maintenance, on page 154](#).

## Shutting down the system

Follow the instructions below to shut down the system.

Step	Action
1	Disconnect the system using <b>System Control</b> → <b>System</b> → <b>Connect to Systems</b> .
2	Select <b>Exit UNICORN</b> from the <b>File</b> menu in any module in the UNICORN software.
3	Press the <b>ON/OFF</b> button on the right hand side of the instrument. The button illumination flashes while the instrument is shutting down.



### WARNING

Power is still supplied to internal electronics circuits when the instrument is switched off using the **ON/OFF** button. Disconnect the instrument from the power supply before maintenance or service.

# 7 Maintenance

## About this chapter

Regular maintenance of the ÄKTA pilot 600 system is essential for reliable function.

This chapter describes the recommended maintenance schedules and provides detailed instructions for maintenance operations that are performed frequently or that are necessary for safe handling of the instrument. Refer to the *ÄKTA pilot 600 User Manual* for detailed instructions for other maintenance operations.

## In this chapter

Section	See page
7.1 Maintenance schedule	156
7.2 Cleaning procedures	158
7.3 Replacement procedures	165

## Precautions



### WARNING

**Electrical shock hazard.** All repairs should be done by service personnel authorized by Cytiva. Do not open any covers or replace parts unless specifically stated in the user documentation.



### WARNING

**Use only approved parts.** Only spare parts and accessories that are approved or supplied by Cytiva may be used for maintaining or servicing the product.

**WARNING**

For continued protection against injury risks due to fluid jets, burst pipes or potentially explosive atmosphere, the user must test the piping system for leakage at maximum operating pressure.

- Always perform a leakage test after assembly or maintenance.
- Always perform a leakage test before operation or CIP.

**WARNING**

**Hazardous chemicals during run.** When using hazardous chemicals, flush the entire system tubing with distilled water, before service and maintenance.

**WARNING**

**Decontaminate before maintenance.** To avoid personnel being exposed to potentially hazardous substances, make sure that the column is properly decontaminated and sanitized before maintenance or service.

**NOTICE**

Remove all columns from the instrument before performing maintenance.

**NOTICE**

Do not allow solutions which contain dissolved salts, proteins or other solid solutes to dry out in the UV flow cell.

## 7.1 Maintenance schedule

### Introduction

Maintenance procedures to be performed by the user are outlined below.

### Periodic maintenance

The following periodic maintenance should be performed by the user of the ÄKTA pilot 600 system.

Interval	Maintenance action	Instructions
Daily or before each run	Calibrate the pH monitor.	<a href="#">Calibrate the pH monitor, on page 126</a>
Daily or weekly	Change pump rinsing solution. <b>Note:</b> <i>Change the pump rinsing solution daily if buffer is used, or weekly if 20% ethanol is used.</i>	<a href="#">Section 7.3.1 Change the pump rinsing solution, on page 166</a>
	Reset the pressure sensors.	See the <a href="#">ÄKTA pilot 600 User Manual</a>
Every 6 months	Clean the UV flow cell.	See the <a href="#">ÄKTA pilot 600 User Manual</a>
	Replace the pH electrode.	<a href="#">Section 4.2.6 Fit the pH electrode, on page 84</a>
Yearly	Replace valve membranes.	<a href="#">Section 7.3.4 Replace valve membranes, on page 171</a>

### Maintenance when required

The following maintenance should be performed when required.

Maintenance action	Instructions
Clean the instrument surfaces	<a href="#">Section 7.2.2 Clean the instrument surfaces, on page 160</a>
Run System CIP (System cleaning-in-place)	<a href="#">Section 7.2.3 Clean the flow path, on page 161</a>
Sanitize the instrument	<a href="#">Section 7.2.3 Clean the flow path, on page 161</a>

Maintenance action	Instructions
Clean and store the pH electrode	<a href="#">Section 7.2.4 Clean and store the pH electrode, on page 163</a>
Clean the conductivity flow cell	See ÄKTA pilot 600 User Manual
Calibrate the conductivity monitor	See ÄKTA pilot 600 User Manual
Replace tubing and connectors	<a href="#">Section 4.2.3 Fit inlet and outlet tubing, on page 72</a>
Replace the UV flow cell	See ÄKTA pilot 600 User Manual
Replace pump rinsing system tubing	<a href="#">Section 7.3.2 Replace pump rinse tubing, on page 168</a>
Replace mains fuses	<a href="#">Section 7.3.5 Replace the main fuses, on page 177</a>
Run performance tests	See ÄKTA pilot 600 User Manual

## 7.2 Cleaning procedures

### About this section

This section describes procedures for cleaning the ÄKTA pilot 600 instrument and components, and also for storing and regenerating the pH electrode.

**Note:** *For column cleaning and storage procedures, refer to the column instructions.*

*Refer to the computer documentation for recommendations for cleaning the computer equipment.*

### In this section

Section	See page
7.2.1 Cleaning before planned service	159
7.2.2 Clean the instrument surfaces	160
7.2.3 Clean the flow path	161
7.2.4 Clean and store the pH electrode	163

## 7.2.1 Cleaning before planned service

### Cleaning before planned maintenance/service

To ensure the protection and safety of service personnel, all equipment and work areas must be clean and free of any hazardous contaminants before a Service Engineer starts maintenance work.

Please complete the checklist in the *On Site Service Health and Safety Declaration Form* or the *Health and Safety Declaration Form for Product Return or Servicing*, depending on whether the instrument is going to be serviced on site or returned for service, respectively.

### Health and safety declaration forms

Health and safety declaration forms are available for copying or printing in the *Reference information* chapter of this manual, or on digital media supplied with the user documentation.

## 7.2.2 Clean the instrument surfaces



### NOTICE

**Cleaning.** Keep the exterior of the instrument dry and clean. Wipe regularly with a soft damp tissue and, if necessary, a mild cleaning agent. Let the instrument dry completely before use.

### Maintenance interval

Clean the the instrument externally when required. Do not allow spilled liquid to dry on the instrument.

### Required material

The following materials are required:

- Cloth
- Mild cleaning agent or 20% ethanol

### Instruction

Follow the instructions to clean the instrument externally.

Step	Action
1	Check that no run is in progress.
2	Switch off the instrument.
3	Wipe the surface with a damp cloth. Wipe off stains using a mild cleaning agent or 20% ethanol. Wipe off any excess.
4	Let the instrument dry completely before using it.



## 7.2.3 Clean the flow path

### Introduction

The flow path should be cleaned regularly. Cleaning is supported by 2 predefined method templates in UNICORN software:

- **System CIP** (Cleaning-in-place), which can be configured to clean selected parts of the flow path using cleaning solutions such as NaOH and NaCl. The predefined **System CIP** method includes by default 3 **System CIP** phases for cleaning with different solutions. Additional CIP phases can be added if required.
- **System Sanitization**, which is used to clean the entire flow system including the pump rinsing system using 1 M NaOH, distilled water, 0.9% NaCl and storage solution or buffer. The **System Sanitization** method is designed to remove microorganisms from the system.



#### NOTICE

The **System Sanitization** method has been verified for selected microorganisms by Cytiva. However, the user is responsible for ensuring that sanitization procedures are adequate for their system.



#### NOTICE

Replace the column(s) with by-pass tubing before running **System Sanitization**, or **System CIP** that includes the **Column Valve**. For instructions on cleaning columns, see the respective column instructions.

**Note:** *The pH electrode is not included in **System CIP** or **System Sanitization** methods. Refer to [Section 7.2.4 Clean and store the pH electrode, on page 163](#) for instructions on how to clean the pH electrode.*

### Maintenance schedule

Run **System CIP** regularly, for example between runs where different samples and buffers are used. Cleaning the flow path is important to prevent cross-contamination and bacterial growth in the instrument.

Run **System Sanitization** after the system has been exposed to bacterial contamination.

Always run **System CIP** or **System Sanitization** using 20% ethanol to fill the flow system as the final step before long-term storage.

Always run **System Sanitization** before maintenance by Cytiva service personnel.

## Required materials

The following items may be required:

- About 85 cm tubing with SNAP connectors (i.d. 3.2 mm) to connect the manual valve on the Air Trap to the Intelligent Packing (**IP**) port on the Column Valve.
- By-pass tubing for both column positions.
- 10 mL syringes (if the pH monitor is to be cleaned).

## Prepare for cleaning

Follow the instructions below to prepare the system for cleaning. Items may be omitted if the corresponding module is not included in **System CIP**. All items should be prepared for **System Sanitization**.

Step	Action
1	Connect by-pass tubing to the column positions on the Column Valve.
2	Connect tubing between the manual valve on top of the Air Trap and the <b>IP</b> port on the Column Valve.
3	Open the manual valve on the Air Trap.
4	Connect tubing to all inlets and outlets, including <b>Waste 2</b> on the Column Valve.
5	Replace the pH electrode in the measuring cell on the pH monitor (if installed) with the dummy electrode. Clean the electrode separately (see <a href="#">Section 7.2.4 Clean and store the pH electrode, on page 163</a> ).
6	Prepare cleaning solutions. Estimated required volumes of each solution are shown on the phase properties page for each phase.
7	Additionally, prepare about 500 mL of each cleaning solution for the pump rinsing system.

## Workflow for cleaning

The workflow for cleaning is described in the steps below.

Step	Action
1	Create and save a method based on the predefined <b>System CIP</b> or <b>System Sanitization</b> method in the UNICORN Method Editor.
2	For <b>System CIP</b> , select the components to be cleaned. This option does not apply to <b>System Sanitization</b> .
3	Start the method.
4	Follow the instructions on the screen. You will be instructed to move the inlet tubing to different cleaning solutions as the method progresses.

## 7.2.4 Clean and store the pH electrode



### NOTICE

Never leave the pH electrode in the flow cell when the system is not in use. This may allow the glass membrane of the electrode to dry out. Place the electrode in the storage position filled with a 1:1 mixture of pH 4 buffer and 1 M  $\text{KNO}_3$ . **Do NOT store in water only.**

### Maintenance interval

Clean the pH electrode when required. The pH electrode has a limited lifetime and should be replaced every six months or when the response time is slow. After cleaning has been performed, re-calibrate the pH monitor (see [Calibrate the pH monitor, on page 126](#) for instructions).

### Cleaning the electrode

Unplug the electrode from the pH module, then use the appropriate cleaning procedure from the table below according to the nature of the deposits:

Deposits	Cleaning procedure
Salt	Dissolve the deposits by immersing the electrode for a five minute period in each of the following solutions. Rinse the electrode tip in distilled water between each solution. <ul style="list-style-type: none"> <li>• 0.1 M HCl</li> <li>• 0.1 M NaOH</li> <li>• 0.1 M HCl</li> </ul>
Oil or grease	Wash the electrode tip in liquid detergent and water. If the films are known to be soluble in a particular organic solvent, wash with this solvent. After cleaning, rinse the electrode tip in distilled water.
Protein	Dissolve protein deposits by immersing the electrode in a solution of 1% pepsin in 0.1 M HCl for five minutes, followed by thorough rinsing with distilled water.

After cleaning, soak the electrode in pH 4 buffer for at least 30 min before calibration and use.

If these procedures fail to restore the electrode performance, try the following procedure.

**Note:** *This procedure can be performed only when the pH electrode is not installed in the cell holder.*

## 7 Maintenance

### 7.2 Cleaning procedures

#### 7.2.4 Clean and store the pH electrode

<b>Step</b>	<b>Action</b>
1	Heat a 1 M $\text{KNO}_3$ solution to 60°C to 80°C.
2	Place the electrode tip in the heated $\text{KNO}_3$ solution.
3	Allow the electrode to cool while immersed in the $\text{KNO}_3$ solution before re-testing.

If the electrode performance is still unsatisfactory, replace the electrode.

### Storing the electrode

Store the electrode in the storage position in a 1:1 mixture of pH 4 buffer and 1 M  $\text{KNO}_3$  whenever it is not in use. Check periodically that the electrode tip is submerged in the storage solution.

### Reconditioning a dry electrode

If the electrode tip dries out it is important to restore the hydrated glass layer. Use the following method to regenerate a dried-out pH electrode.

<b>Step</b>	<b>Action</b>
1	Rinse the electrode carefully with deionized water.
2	Soak the electrode in 0.1 M HCl for 1 hour.
3	Soak the electrode overnight in pH 4 buffer.

If the electrode performance is still unsatisfactory, replace the electrode.

## 7.3 Replacement procedures

### About this section

This section gives instructions for the replacement procedures to be performed by the user of ÄKTA pilot 600 instrument.

### In this section

Section	See page
7.3.1 Change the pump rinsing solution	166
7.3.2 Replace pump rinse tubing	168
7.3.3 Replace flow path tubing and connectors	170
7.3.4 Replace valve membranes	171
7.3.5 Replace the main fuses	177

## 7 Maintenance

### 7.3 Replacement procedures

#### 7.3.1 Change the pump rinsing solution

### 7.3.1 Change the pump rinsing solution

#### Pump rinsing solutions

The recommended pump rinsing solution is 20% ethanol. Using this solution will help to prevent bacterial growth in the pump rinsing system.

Buffer or distilled water may also be used if desired.

If you change to a different pump rinsing solution, make sure that the old and new solutions do not precipitate on mixing, or rinse the system thoroughly with distilled water between solutions.

**Note:** *Change the solution daily if buffer or water is used as pump rinsing solution.*

#### Maintenance interval

Replace the pump rinsing solution at regular intervals according to the rinsing solution used.

Rinsing solution	Replacement interval
20% ethanol	Every week
Buffer or water	Every day, to prevent bacterial growth

#### Required material

The following material are required:

- Pump rinsing solution (500 mL)

#### Procedure

Follow the instructions below to change the pump rinsing solutions.

Step	Action
------	--------

- |   |                                      |
|---|--------------------------------------|
| 1 | Make sure the pumps are not running. |
|---|--------------------------------------|

Step	Action
------	--------

- |   |   |
|---|---|
| 2 | Pull out the two pump rinsing bottles from the holders. |
|---|---|



**Note:**

*You may need to push the lower part of the bottle holders downwards to release the bottles.*

- |   |  |
|---|--|
| 3 | Empty and rinse out the bottles.   |
| 4 | Fill each bottle with 250 mL pump rinsing solution.  |
| 5 | Insert the tubing into the corresponding bottle and make sure that both tubes are placed below the liquid surface. |



**Note:**

*The pump rinsing system operates when the pumps are running.*

- |   |                                     |
|---|-------------------------------------|
| 6 | Replace the bottles in the holders. |
|---|-------------------------------------|

## 7.3.2 Replace pump rinse tubing

### Maintenance interval

Replace the pump rinsing system tubing when required, for example if the tubing is clogged or damaged.

### Required material

The following material is required:

- Rinsing system tubing

### Illustration of the pump piston rinsing systems

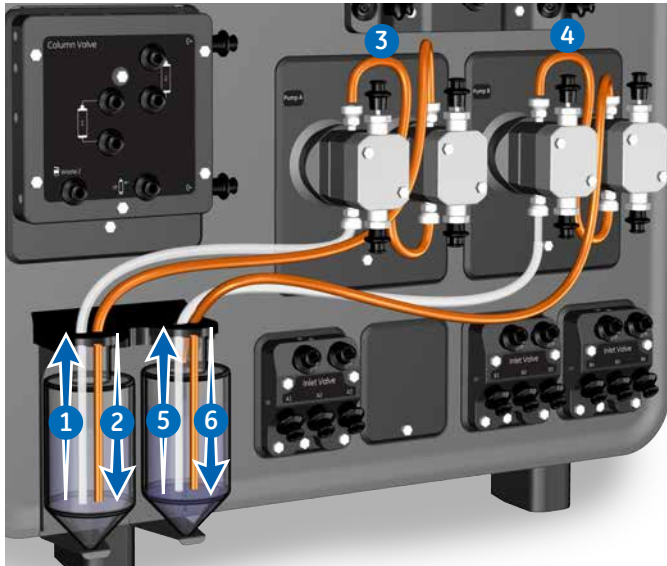

Part	Description
1	Inlet tubing to <b>Pump A</b> (Pump A) piston rinsing system
2	Outlet tubing from <b>Pump A</b> (Pump A) piston rinsing system
3	Intermediate tubing between <b>Pump A</b> (Pump A) pump heads
4	Intermediate tubing between <b>Pump B</b> (Pump B) pump heads
5	Inlet tubing to <b>Pump B</b> (Pump B) piston rinsing system
6	Outlet tubing from <b>Pump B</b> (Pump B) piston rinsing system



## Connect new tubing

Step	Action
1	Disconnect the used tubing.
2	Connect the new tubing according to the illustration above.  <b>Note:</b> <i>Fit the clips from the original pump rinsing tubing. Do not attempt to use SNAP connectors.</i>
3	Refill the pump rinsing system (see <a href="#">Section 7.3.1 Change the pump rinsing solution, on page 166</a> ).

## 7 Maintenance

### 7.3 Replacement procedures

#### 7.3.3 Replace flow path tubing and connectors

### 7.3.3 Replace flow path tubing and connectors

#### Maintenance interval

Replace tubing and connectors when required, for example when a tubing has clogged or has become kinked so that the flow is stopped or when the end of the tubing is worn and there is a risk for leakage.

#### Required material

The following materials are required:

- Tubing and connectors
- Tubing cutter
- Tube bender

#### Procedure

See [Section 3.3 Tubing and connectors, on page 33](#) for instructions on connecting and disconnecting tubing.

Replace tubing with pieces of the same length. If tubing lengths between the detector and the outlet valves are changed, the delay volume will need to be adjusted (see [Section 4.7 Delay volumes, on page 115](#)).

## 7.3.4 Replace valve membranes

### Introduction

This section describes when and how to replace the valve membranes in the ÄKTA pilot 600 instrument.

### Valves with replaceable membranes

The instructions in this section apply to membranes in the valves listed below. The procedure for replacing valve membranes is the same for all valves, although the number of membranes varies between the valves. Valve membranes are supplied in kits with three membranes per kit.

Valve	Number of membranes	Number of membrane kits
Inlet valve	3	1
Mixer valve	3	1
Air trap valve	3	1
Column valve	12	4
Outlet valve	3	1

Illustrations in this section show the Air trap valve.

### When to replace the valve membranes

Replace the valve membranes at least once a year or whenever leakage of liquid is observed at the lower edge of the valve housing, as indicated in the illustration below.



All membranes in a given valve should be replaced at the same time.

## Required tools

Tool	Dimension
Torque wrench, up to 3.5 Nm (not supplied)	7 mm

## Procedure

Follow the instructions below to replace the valve membranes. Do not switch off the instrument during membrane replacement.

**Note:** In the instructions below, the term **<valve name>** refers to the name of the valve where the membrane is to be changed, for example, **Inlet valve A** or **Mixer valve**. The images below show the **Air Trap** valve.

- | Step | Action   |
|------|--|
| 1    | Empty the flow path and the Air Trap.<br>If there is liquid in the flow path adjacent to the valve in question, the liquid will drain from the valve front when the front is removed.                                |
| 2    | Disconnect all tubing from the valve.<br>This will make it easier to access the valve front.   |
| 3    | Select <b>Manual</b> → <b>Execute Manual Instructions</b> in the UNICORN System Control module   |
| 4    | Expand the <b>Maintenance</b> section and select <b>&lt;valve name&gt; maintenance position</b> . Set <b>Position</b> to <b>Open All</b> and click <b>Execute</b> . Leave the <b>Manual Instruction</b> dialog open. |

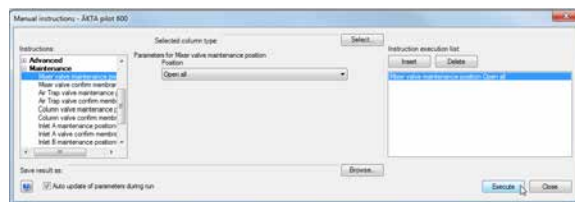

**Result:**

the valve plungers move a few mm into the valve body.

Step	Action
5	Remove the bolts that secure the valve front to the instrument. There are 6 bolts on the Column Valve and 3 on other valves.



**Air Trap Valve** and other valves



**Column Valve**



**NOTICE**

Remove only the bolts indicated in the illustrations above. Do not remove any other bolts.

6	Remove the valve front (A). Make sure that the sealing ring (B) remains securely in place on the valve body.
---	--

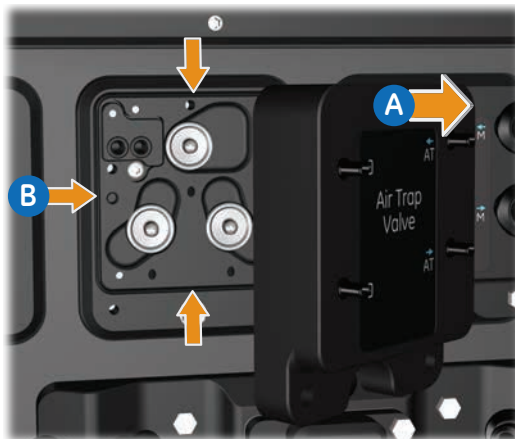

Step	Action
------	--------

- |   |   |
|---|---|
| 7 | Set <b>&lt;valve name&gt; maintenance position</b> to <b>Closed</b> in the UNICORN software and click <b>Execute</b> . Leave the <b>Manual Instruction</b> dialog open. |
|---|---|

*Result:*

the valve plungers move a few mm out of the valve body.

- |   |   |
|---|---|
| 8 | Remove the old valve membranes from the valve body. |
|---|---|



- |   |   |
|---|---|
| 9 | Remove the protective backing from each new membrane. |
|---|---|

- |    |   |
|----|---|
| 10 | Fit the new valve membranes on to the valve plungers (A). Make sure that the plungers are fully inserted into the seating on the valve membranes (B). |
|----|---|



Step	Action
11	<p>Set <b>&lt;valve name&gt; maintenance position</b> to <b>Open All</b> in the UNICORN software.</p> <p><i>Result:</i></p> <p>the valve plungers with the new membranes move a few mm into the valve body. Make sure that the membranes are correctly seated in the valve body.</p>
12	<p>Replace the valve front on the valve body and secure it with the bolts.</p> <p>Tighten all the bolts first by hand, then tighten to torque 2.5 to 3.5 Nm using a torque wrench.</p>



#### NOTICE

Make sure that the valve plungers are retracted into the valve body before fitting the valve front. Attempting to fit the front without issuing the **Open All** command in the software may damage the valve membrane.

13	Reconnect all tubing to the valve if it was disconnected at the start of the procedure.
14	Press <b>End</b> if you do not want to reset the valve usage statistics.

## Reset valve usage statistics

Follow the instructions below to reset the valve usage statistics in the UNICORN software when the valve membranes have been replaced.

**Step Action**

- 1 Select **<valve name> confirm membrane change** in the UNICORN software **Manual Instructions** dialog. Click **Execute**.



- 2 Close the **Manual Instructions** dialog.
- 3 Click the **End** button on the UNICORN toolbar to put the system in the **Ready** state.

**Result:**

The valve usage statistics are reset.

The statistics can be viewed in the **System** → **Maintenance Manager** dialog.

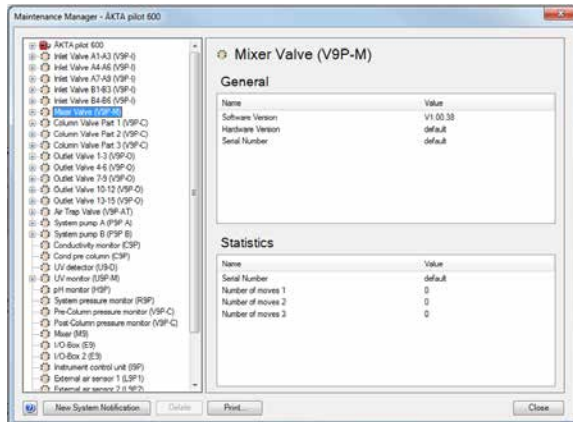



## 7.3.5 Replace the main fuses



### WARNING

**Disconnect power.** Always disconnect power from the instrument before replacing fuses.



### WARNING

For continued protection from fire hazard, replace only with same type and rating of fuse.



### WARNING

If a fuse requires repeated replacement, do not continue to use the instrument. Contact an authorized service engineer.

## Required tools

Tool	Dimension
Flat screwdriver	2 to 3 mm

## Procedure

Follow the instructions below to replace the fuses.

**Note:** *There are two identical fuses at the mains power inlet. Replace both fuses even if only one is blown.*

Step	Action
------	--------

1	Disconnect the power cord from the power inlet.
---	---

Step	Action
------	--------

- |   |   |
|---|---|
| 2 | Use a small flat-bladed screwdriver to prise open the fuse holder cover on the power inlet. |
|---|---|



- |   |  |
|---|--|
| 3 | Pull the fuse holder out of the mains connector panel by hand. |
| 4 | Remove the fuses from the fuse holder.                         |
| 5 | Fit new fuses of the same size and rating.                     |
| 6 | Replace the fuse holder in the power inlet.                    |



**NOTICE**

When replacing fuses, make sure that the fuse holder is pushed fully into position.

- |   |                           |
|---|---------------------------|
| 7 | Reconnect the power cord. |
|---|---------------------------|

# 8 Troubleshooting

## About this chapter

This chapter provides information for basic troubleshooting of the ÄKTA pilot 600 system. Troubleshooting software problems is covered in the UNICORN documentation.

This chapter does not cover troubleshooting for chromatography applications. Publications describing general chromatography principles and practice are available from Cytiva.

If you cannot resolve problems using the information provided here, call your Cytiva service representative.

## System error report

When you request troubleshooting assistance from Cytiva, you should generate a **System error report** (system error report) and submit it to your service representative.

Follow the instructions below to generate a **System error report**.

Step	Action
1	Select <b>Create System Error Report</b> from the <b>System</b> menu in the <b>System Control</b> module. Users with sufficient access rights can also create a <b>System error report</b> from the <b>Administration</b> module.
2	Step through the report wizard using the <b>Next</b> and <b>Back</b> buttons. Provide information as requested at each step. Add results, methods and logs as appropriate.
3	Save the report in the default folder or a folder of your choice. The report is saved as a zip file with the name <b>Report_YYYYMMDDnn.zip</b> .
4	Submit the file to your Cytiva service representative.
	<b>Note:</b> <i>The file may be large (&gt; 15 Mb).</i>

## Startup problems

Problem	Possible cause and action
<b>The ÄKTA pilot 600 instrument does not start.</b>	<ul style="list-style-type: none"> <li>• <b>Faulty power supply</b> Check the power outlet and power cord.</li> <li>• <b>Fuse needs replacing</b> See <a href="#">Section 7.3.5 Replace the main fuses, on page 177</a>.</li> </ul> <p>If the problem persists, call your Cytiva service representative.</p>

## Software and communication problems

Problem	Possible cause and action
<b>Unable to connect to the instrument in the UNICORN software or the instrument does not respond to software instructions</b>	<ul style="list-style-type: none"> <li>• <b>System not connected in UNICORN software</b> Check that UNICORN is correctly installed and that the correct system is defined and connected. See the UNICORN documentation.</li> <li>• <b>Faulty communication cable</b> Check the communication cable.</li> <li>• <b>UniNet-9 communication failure</b> Check that all externally connected modules are correctly installed and that all unused UniNet-9 connectors on the back panel are fitted with a jumper.</li> </ul>
<b>Error message in the UNICORN software</b>	<p>Follow any instructions in the message dialog. See the UNICORN documentation for further details.</p> <p>If the problem persists, call your Cytiva service representative.</p>

## Pump rinsing system problems

Problem	Possible cause and action
<b>The level of liquid in the pump rinsing bottles increases</b>	<ul style="list-style-type: none"> <li>• <b>Pump maintenance is required</b> Call your Cytiva service representative.</li> </ul>

## Flow path problems

Problem	Possible cause and action
<b>Leakage from a valve front</b>	<ul style="list-style-type: none"> <li>• <b>Valve membranes need replacing</b> See <a href="#">Section 7.3.4 Replace valve membranes, on page 171</a>.</li> </ul>
<b>Leakage from a tubing connection</b>	<ul style="list-style-type: none"> <li>• <b>Tubing and SNAP connector not correctly fitted</b> Replace the tubing. See <a href="#">Section 3.3 Tubing and connectors, on page 33</a>.</li> </ul>
<b>Unexpectedly high pressure or low outlet flow</b>	<ul style="list-style-type: none"> <li>• <b>Tubing obstructed</b> Check that the tubing is not twisted or kinked. Replace tubing if necessary.</li> </ul>
<b>Air in the flow path</b>	<ul style="list-style-type: none"> <li>• <b>System not correctly primed</b> Prime the flow path (see <a href="#">Section 5.4 Prime the flow path, on page 130</a>).</li> </ul>
<b>Pressure alarm issued</b>	<ul style="list-style-type: none"> <li>• Change the appropriate valve position using a manual command in the software.</li> <li>• Open the air vent on the Air Trap to release the pressure.</li> <li>• Press <b>End</b> to stop the run.</li> </ul>

# 9 Reference information

## About this chapter

This chapter provides reference information for the ÄKTA pilot 600 system.

Refer to the *ÄKTA pilot 600 Product Documentation* for additional details and for specific information relating to your system.

## In this chapter

<b>Section</b>	<b>See page</b>
9.1 System specifications	183
9.2 Tubing and connectors	184
9.3 Chemical resistance guide	185
9.4 Recycling information	189
9.5 Regulatory information	190
9.6 Health and Safety Declaration Form	200

## 9.1 System specifications

### Technical specifications

Parameter	Data
System configuration	Benchtop system, external computer
Control system	UNICORN 7.3 or later version
Connection between PC and instrument	Ethernet
Dimensions (width × height × depth)	575 × 865 × 510 mm
Weight (excluding computer, columns, buffer bottles)	77 to 84 kg <sup>1</sup>
Power supply	100 to 240 V~ autorange
Maximum voltage fluctuation	± 10% from the nominal voltage
Frequency	50/60 Hz
Power consumption	800 VA
Enclosure protective class	IP 23
Enclosure protective class for Extension Box	IP 21

<sup>1</sup> Depending on configuration.

### Equipment noise level

Equipment	Acoustic noise level
ÄKTA pilot 600 instrument	< 70 dB(A)

### Battery information

The instrument contains a lithium backup battery. The battery cannot be replaced by the user.

## 9.2 Tubing and connectors

### Introduction

This section describes the tubing and connectors that are used with the ÄKTA pilot 600 system.

### Tubing

Tubing dimensions are given in the table below.

Location	i.d. <sup>1</sup> (approx)	o.d. <sup>2</sup> (approx)	Material	Volume/cm
Pump rinsing system	2.4 mm	5.6 mm	Silicone	
Inlet Inlet valve to pump	4.8 mm	6.4 mm	FEP	0.18 mL
All other tubing	3.2 mm	4.8 mm	FEP	0.08 mL

<sup>1</sup> inner diameter

<sup>2</sup> outer diameter

Tubing is supplied in lengths of 30 m for i.d. 3.2 mm and 15 m for i.d. 4.8 mm. Cut the required length of tubing according to where it will be used.

### Tubing connectors

ÄKTA pilot 600 system uses SNAP connectors for all tubing connections except the pump rinsing system. How to use SNAP connectors is described in [Section 3.3 Tubing and connectors, on page 33](#).



## 9.3 Chemical resistance guide

### Introduction

This section provides general information about biocompatibility and detailed information about chemical resistance of the ÄKTA pilot 600 instrument.



#### NOTICE

The information in this section applies to the ÄKTA pilot 600 instrument. Refer to the column instructions for chemical resistance information relating the columns used.

### In this section

Section	See page
9.3.1 General information	186
9.3.2 Chemical resistance specifications	187

## 9.3.1 General information

### Biocompatibility

The ÄKTA pilot 600 instrument is designed for maximum biocompatibility, with biochemically inert flow paths constructed mainly from titanium, PEEK and highly resistant fluoropolymers and fluoroelastomers. Plastics and rubber materials are selected to avoid leakage of monomers, plasticizers or other additives.

### Cleaning and sanitization

Cleaning usually works well with 1 M sodium hydroxide or 70% acetic acid. Hydrochloric acid can be used up to a concentration of 0.1 M. Higher concentrations may damage the pressure sensors.

For sanitization, repeated cleaning cycles with 1 M sodium hydroxide, distilled water, and 0.9% NaCl are recommended (see [Section 7.2.3 Clean the flow path, on page 161](#)).

If sodium hypochlorite is used as sanitizing agent instead of sodium hydroxide, use concentrations up to 10%.

### Organic solvents

The system is not intended for reversed phase chromatography (RPC). The system is not approved for handling flammable liquids or working in a potentially explosive atmosphere.



#### WARNING

**Flammable liquids.** This product is **not approved** for handling flammable liquids.



#### WARNING

**Explosive environment.** The product is **not approved** for work in a potentially explosive atmosphere. The product does not fulfill the requirements of the ATEX Directive.

### Assumptions

The chemical resistance specifications are based on the following assumptions:

- Synergy effects of chemical mixtures have not been taken into account.
- Room temperature and limited overpressure is assumed.

**Note:** *Chemical influences are time and pressure dependent. Unless otherwise stated, all concentrations are 100%.*

## 9.3.2 Chemical resistance specifications

### Introduction

This section provides detailed information about chemical resistance of the ÄKTA pilot 600 instrument to some common aggressive chemicals used in liquid chromatography. For information regarding chemicals not listed in this section, contact your Cytiva representative.

**Note:** Refer to Safety Data Sheets (SDS) for information regarding characteristics, human and environmental risks and preventive measures for chemicals used. Make sure that you have the SDS available from your chemical distributor and/or databases on the internet.

### Scope

The information in this section applies to the ÄKTA pilot 600 flow path. Recommended solutions for the pump rinsing system are aqueous buffers pH 2 to 12 or ethanol up to 20%. Do not use other chemicals in the pump rinsing system.

### Chemical resistance, short term

The following chemicals are suitable for up to 2 h contact time at room temperature.

Chemical	Concentration	CAS no	EC no
Acetic acid	70%	75-05-8	200-835-2
Decon™ 90	10%	N/A	N/A
Ethanol	70%	75-08-1	200-837-3
Hydrochloric acid	0.1 M	7647-01-0	231-595-7
Isopropanol	30%	67-63-0	200-661-7
Sodium hydroxide	2 M	1310-73-2	215-185-5
Sodium hydroxide/ethanol	1 M/40%	N/A	N/A
Sodium chloride	4 M	7647-14-5	231-598-3
Sodium hypochlorite	10%	7681-52-9	231-668-3

### Chemical resistance, long term

The following chemicals are suitable for continuous use at 4°C to 35°C.

Chemical	Concentration	CAS no	EC no
Aqueous buffers, pH 2 to 12	N/A	N/A	N/A
Acetone	10%	67-64-1	200-662-2

## 9 Reference information

### 9.3 Chemical resistance guide

#### 9.3.2 Chemical resistance specifications

Chemical	Concentration	CAS no	EC no
Ammonia	30%	7664-41-7	231-635-3
Ammonium chloride	2 M	12125-02-9	235-186-4
Ammonium sulfate	3 M	7783-20-2	231-984-1
Arginine	2 M	74-79-3	200-811-1
Benzyl alcohol	2%	100-51-6	202-859-9
Dimethyl sulfoxide (DMSO)	5%	67-68-5	200-664-3
Dithioerythritol (DTE)	100 mM	6892-68-8	229-998-8
Dithiothreitol (DTT)	100 mM	3483-12-3	222-468-7
Ethanol for long-term storage	20%	75-08-1	200-837-3
Ethylene glycol	50%	107-21-1	203-473-3
Ethylenediaminetetraacetic acid (EDTA)	100 mM	60-00-4	200-449-4
Glycerol	50%	56-81-5	200-289-5
Guanidinium hydrochloride	6 M	50-01-1	200-002-3
Mercaptoethanol	20 mM	37482-11-4	253-523-3
Phosphoric acid	0.1 M	7664-38-2	231-633-2
Potassium chloride	4 M	7447-40-7	231-211-8
Sodium dodecyl sulfate (SDS)	1%	151-21-3	205-788-1
Sodium hydroxide	0.01 M	1310-73-2	215-185-5
Tween™ 20	1%	9005-64-5	500-018-3
Urea	8 M	57-13-6	200-315-5

## 9.4 Recycling information

### Introduction

This section contains information about the decommissioning of ÄKTA pilot 600.



#### **CAUTION**

Always use appropriate personal protective equipment when decommissioning the equipment.

### Decontamination

The product must be decontaminated before decommissioning. All local regulations must be followed with regard to scrapping of the equipment.

### Disposal of the product

When taking the product out of service, the different materials must be separated and recycled according to national and local environmental regulations.

### Recycling of hazardous substances

The product contains hazardous substances. Detailed information is available from your Cytiva representative.

### Disposal of electrical components



Waste electrical and electronic equipment must not be disposed of as unsorted municipal waste and must be collected separately. Contact an authorized representative of the manufacturer for information concerning the decommissioning of the equipment.

### Disposal of batteries

Waste batteries and accumulators must not be disposed of as unsorted municipal waste and must be collected separately. Follow applicable local regulations for recycling of batteries and accumulators.

The instrument contains a lithium battery which must not be disposed of in fire.

## 9.5 Regulatory information

### Introduction

This section lists the regulations and standards that apply to the product.

### In this section

<b>Section</b>	<b>See page</b>
9.5.1 Contact information	191
9.5.2 European Union and European Economic Area	192
9.5.3 Eurasian Economic Union Евразийский экономический союз	193
9.5.4 Regulations for North America	195
9.5.5 Regulatory statements	196
9.5.6 Declaration of Hazardous Substances (DoHS)	197
9.5.7 Other regulations and standards	199

## 9.5.1 Contact information

### Contact information for support

To find local contact information for support and sending troubleshooting reports, visit [cytiva.com/contact](https://cytiva.com/contact).

### Manufacturing information

The table below summarizes the required manufacturing information.

Requirement	Information
Name and address of manufacturer	Cytiva Sweden AB Björkgatan 30 SE 751 84 Uppsala Sweden
Telephone number of manufacturer	+ 46 771 400 600

## 9 Reference information

### 9.5 Regulatory information

#### 9.5.2 European Union and European Economic Area

## 9.5.2 European Union and European Economic Area

### Introduction

This section describes regulatory information for the European Union and European Economic Area that applies to the equipment.

### Conformity with EU Directives

See the EU Declaration of Conformity for the directives and regulations that apply for the CE marking.

If not included with the product, a copy of the EU Declaration of Conformity is available on request.

### CE marking



The CE marking and the corresponding EU Declaration of Conformity is valid for the instrument when it is:

- used according to the *Operating Instructions* or user manuals, and
- used in the same state as it was delivered, except for alterations described in the *Operating Instructions* or user manuals.



## 9.5.3 Eurasian Economic Union Евразийский экономический союз

This section describes the information that applies to the product in the Eurasian Economic Union (the Russian Federation, the Republic of Armenia, the Republic of Belarus, the Republic of Kazakhstan, and the Kyrgyz Republic).

### Introduction

This section provides information in accordance with the requirements of the Technical Regulations of the Customs Union and (or) the Eurasian Economic Union.

### Введение

В данном разделе приведена информация согласно требованиям Технических регламентов Таможенного союза и (или) Евразийского экономического союза.

### Manufacturer and importer information

The following table provides summary information about the manufacturer and importer, in accordance with the requirements of the Technical Regulations of the Customs Union and (or) the Eurasian Economic Union.

Requirement	Information
Name, address and telephone number of manufacturer	See <i>Manufacturing information</i>
Importer and/or company for obtaining information about importer	LLC Global Life Sciences Solutions Rus Russian Federation, 123112 Presnenskaya nab., 10, fl. 12, pr. III, room 6 Telephone: + 7 495 739 6931 Fax nr: + 7 495 739 6932 E-mail: <a href="mailto:rucis@cytiva.com">rucis@cytiva.com</a>

### Информация о производителе и импортере

В следующей таблице приводится сводная информация о производителе и импортере, согласно требованиям Технических регламентов Таможенного союза и (или) Евразийского экономического союза.

Требование	Информация
Наименование, адрес и номер телефона производителя	См. <i>Информацию об изготовлении</i>

## 9 Reference information

### 9.5 Regulatory information

#### 9.5.3 Eurasian Economic Union

Евразийский экономический союз

Требование	Информация
Импортер и/или лицо для получения информации об импортере	ООО "Глобал Лайф Сайэнсиз Солюшнз Рус" Российская Федерация, 123112 Пресненская наб., д. 10, эт. 12, пом. III, ком. 6 Телефон: + 7 495 739 6931 Факс: + 7 495 739 6932 Адрес электронной почты: <a href="mailto:rucis@cytiva.com">rucis@cytiva.com</a>

## Description of symbol on the system label

### Описание обозначения на этикетке системы



This Eurasian compliance mark indicates that the product is approved for use on the markets of the Member States of the Customs Union of the Eurasian Economic Union

Данный знак о Евразийском соответствии указывает, что изделие одобрено для использования на рынках государств-членов Таможенного союза Евразийского экономического союза

## 9.5.4 Regulations for North America

### Introduction

This section describes the information that applies to the product in the USA and Canada.

### FCC compliance

This device complies with part 15 of the FCC Rules. Operation is subject to the following two conditions: (1) This device may not cause harmful interference, and (2) this device must accept any interference received, including interference that may cause undesired operation.

**Note:** *The user is cautioned that any changes or modifications not expressly approved by Cytiva could void the user's authority to operate the equipment.*

This equipment has been tested and found to comply with the limits for a Class A digital device, pursuant to part 15 of the FCC Rules. These limits are designed to provide reasonable protection against harmful interference when the equipment is operated in a commercial environment. This equipment generates, uses, and can radiate radio frequency energy and, if not installed and used in accordance with the instruction manual, may cause harmful interference to radio communications. Operation of this equipment in a residential area is likely to cause harmful interference in which case the user will be required to correct the interference at his own expense.

## 9.5.5 Regulatory statements

### Introduction

This section shows regulatory statements that apply to regional requirements.

### EMC emission, CISPR 11: Group 1, Class A statement



#### NOTICE

This equipment is not intended for use in residential environments and may not provide adequate protection to radio reception in such environments.

### South Korea

Regulatory information to comply with the Korean technical regulations.



#### NOTICE

Class A equipment (equipment for business use).

This equipment has been evaluated for its suitability for use in a business environment.

When used in a residential environment, there is a concern of radio interference.



#### 주의

A급 기기(업무용 방송통신기자재)

이 기기는 업무용 환경에서 사용할 목적으로 적합성평가를 받은 기기

로서 가정용 환경에서 사용하는 경우 전파간섭의 우려가 있습니다.

## 9.5.6 Declaration of Hazardous Substances (DoHS)

根据 SJ/T11364-2014 《电子电气产品有害物质限制使用标识要求》特提供如下有关污染控制方面的信息。

The following product pollution control information is provided according to SJ/T11364-2014 Marking for Restriction of Hazardous Substances caused by electrical and electronic products.

### 电子信息产品污染控制标志说明 Explanation of Pollution Control Label



该标志表明本产品含有超过中国标准 GB/T 26572 《电子电气产品中限用物质的限量要求》中限量的有害物质。标志中的数字为本产品的环保使用期，表明本产品在正常使用的条件下，有毒有害物质不会发生外泄或突变，用户使用本产品不会对环境造成严重污染或对其人身、财产造成严重损害的期限。单位为年。

为保证所声明的环保使用期限，应按产品手册中所规定的环境条件和方法进行正常使用，并严格遵守产品维修手册中规定的定期维修和保养要求。

产品中的消耗件和某些零部件可能有其单独的环保使用期限标志，并且其环保使用期限有可能比整个产品本身的环保使用期限短。应到期按产品维修程序更换那些消耗件和零部件，以保证所声明的整个产品的环保使用期限。

本产品在使用寿命结束时不可作为普通生活垃圾处理，应被单独收集妥善处理。

This symbol indicates the product contains hazardous materials in excess of the limits established by the Chinese standard GB/T 26572 Requirements of concentration limits for certain restricted substances in electrical and electronic products. The number in the symbol is the Environment-friendly Use Period (EFUP), which indicates the period during which the hazardous substances contained in electrical and electronic products will not leak or mutate under normal operating conditions so that the use of such electrical and electronic products will not result in any severe environmental pollution, any bodily injury or damage to any assets. The unit of the period is "Year".

In order to maintain the declared EFUP, the product shall be operated normally according to the instructions and environmental conditions as defined in the product manual, and periodic maintenance schedules specified in Product Maintenance Procedures shall be followed strictly.

Consumables or certain parts may have their own label with an EFUP value less than the product. Periodic replacement of those consumables or parts to maintain the declared EFUP shall be done in accordance with the Product Maintenance Procedures.

This product must not be disposed of as unsorted municipal waste, and must be collected separately and handled properly after decommissioning.

## 9 Reference information

### 9.5 Regulatory information

#### 9.5.6 Declaration of Hazardous Substances (DoHS)

## 有害物质的名称及含量

### Name and Concentration of Hazardous Substances

产品中有害物质的名称及含量

Table of Hazardous Substances' Name and Concentration

部件名称 Component name	有害物质 Hazardous substance					
	铅 (Pb)	汞 (Hg)	镉 (Cd)	六价铬 (Cr(VI))	多溴联苯 (PBB)	多溴二苯醚 (PBDE)
29274325	X	0	0	0	0	0
29228277	X	0	0	0	0	0
29225980	X	0	0	0	0	0
29231714	X	0	0	0	0	0
29011361	X	0	0	0	0	0
29274543	X	0	0	0	0	0
29274544	X	0	0	0	0	0
29274545	X	0	0	0	0	0
29274546	X	0	0	0	0	0

- 0:** 表示该有害物质在该部件所有均质材料中的含量均在 GB/T 26572 规定的限量要求以下。
- X:** 表示该有害物质至少在该部件的某一均质材料中的含量超出 GB/T 26572 规定的限量要求。
- 此表所列数据为发布时所能获得的最佳信息。
- 0:** Indicates that this hazardous substance contained in all of the homogeneous materials for this part is below the limit requirement in GB/T 26572.
- X:** Indicates that this hazardous substance contained in at least one of the homogeneous materials used for this part is above the limit requirement in GB/T 26572
- Data listed in the table represents best information available at the time of publication.

## 9.5.7 Other regulations and standards

### Introduction

This section describes the standards that apply to the product.

### Biological and chemical compatibility

The Wetted parts of the ÄKTA pilot 600 instrument meet the material requirements of the following standards and regulations:

Requirement	Description
USP <88> Class VI	Material requirements from United States Pharmacopeia. Biological Reactivity Tests, "In Vivo".
EMA/410/01	Guidance on minimising the risk of transmitting animal spongiform encephalopathy agents via human and veterinary medicinal products. Animal origin-free material.
21 CFR 177	Indirect food additives: Polymers

## 9.6 Health and Safety Declaration Form

### On site service



### On Site Service Health & Safety Declaration Form

<b>Service Ticket #:</b>	
--------------------------	--

To make the mutual protection and safety of Cytiva service personnel and our customers, all equipment and work areas must be clean and free of any hazardous contaminants before a Service Engineer starts a repair. To avoid delays in the servicing of your equipment, complete this checklist and present it to the Service Engineer upon arrival. Equipment and/or work areas not sufficiently cleaned, accessible and safe for an engineer may lead to delays in servicing the equipment and could be subject to additional charges.

Yes	No	Review the actions below and answer "Yes" or "No". Provide explanation for any "No" answers in box below.
<input type="radio"/>	<input type="radio"/>	<b>Instrument has been cleaned of hazardous substances.</b> Rinse tubing or piping, wipe down scanner surfaces, or otherwise make sure removal of any dangerous residue. Make sure the area around the instrument is clean. If radioactivity has been used, perform a wipe test or other suitable survey.
<input type="radio"/>	<input type="radio"/>	<b>Adequate space and clearance is provided to allow safe access</b> for instrument service, repair or installation. In some cases this may require customer to move equipment from normal operating location prior to Cytiva arrival.
<input type="radio"/>	<input type="radio"/>	<b>Consumables, such as columns or gels, have been removed or isolated from the instrument and from any area that may impede access to the instrument.</b>
<input type="radio"/>	<input type="radio"/>	<b>All buffer / waste vessels are labeled.</b> <b>Excess containers have been removed from the area to provide access.</b>
<b>Provide explanation for any "No" answers here:</b>		
<b>Equipment type / Product No:</b>		<b>Serial No:</b>
I hereby confirm that the equipment specified above has been cleaned to remove any hazardous substances and that the area has been made safe and accessible.		
<b>Name:</b>		<b>Company or institution:</b>
<b>Position or job title:</b>		<b>Date (YYYY/MM/DD):</b>
<b>Signed:</b>		

Cytiva and the Drop logo are trademarks of Global Life Sciences IP Holdco LLC or an affiliate.

© 2020 Cytiva.  
 All goods and services are sold subject to the terms and conditions of sale of the supplying company operating within the Cytiva business. A copy of those terms and conditions is available on request. Contact your local Cytiva representative for the most current information.

For local office contact information, visit [cytiva.com/contact](http://cytiva.com/contact).  
 28980026 AD 04/2020



## Product return or servicing



### Health & Safety Declaration Form for Product Return or Servicing

<b>Return authorization number:</b>		<i>and/or</i> <b>Service Ticket/Request:</b>	
-------------------------------------	--	---	--

To make sure the mutual protection and safety of Cytiva personnel, our customers, transportation personnel and our environment, all equipment must be clean and free of any hazardous contaminants before shipping to Cytiva. To avoid delays in the processing of your equipment, complete this checklist and include it with your return.

- Note that items will NOT be accepted for servicing or return without this form
- Equipment which is not sufficiently cleaned prior to return to Cytiva may lead to delays in servicing the equipment and could be subject to additional charges
- Visible contamination will be assumed hazardous and additional cleaning and decontamination charges will be applied

Yes	No	Specify if the equipment has been in contact with any of the following:	
<input type="radio"/>	<input type="radio"/>	Radioactivity (specify)	
<input type="radio"/>	<input type="radio"/>	Infectious or hazardous biological substances (specify)	
<input type="radio"/>	<input type="radio"/>	Other Hazardous Chemicals (specify)	

**Equipment must be decontaminated prior to service / return. Provide a telephone number where Cytiva can contact you for additional information concerning the system / equipment.**

<b>Telephone No:</b>			
<b>Liquid and/or gas in equipment is:</b>	<input type="checkbox"/>	Water	
	<input type="checkbox"/>	Ethanol	
	<input type="checkbox"/>	None, empty	
	<input type="checkbox"/>	Argon, Helium, Nitrogen	
	<input type="checkbox"/>	Liquid Nitrogen	
		<input type="checkbox"/>	Other, specify
<b>Equipment type / Product No:</b>		<b>Serial No:</b>	

**I hereby confirm that the equipment specified above has been cleaned to remove any hazardous substances and that the area has been made safe and accessible.**

<b>Name:</b>		<b>Company or institution:</b>	
<b>Position or job title:</b>		<b>Date (YYYY/MM/DD)</b>	
<b>Signed:</b>			

Cytiva and the Drop logo are trademarks of Global Life Sciences IP Holdco LLC or an affiliate.

© 2020 Cytiva.

All goods and services are sold subject to the terms and conditions of sale of the supplying company operating within the Cytiva business. A copy of those terms and conditions is available on request. Contact your local Cytiva representative for the most current information.

For local office contact information, visit [cytiva.com/contact](http://cytiva.com/contact).  
28980027 AD 04/2020

**To receive a return authorization number or service number, call local technical support or customer service.**

# Index

## A

- Accessories, 38, 42–45
  - extension box, 43
  - extension stand, 44
  - external air sensors, 38
  - I/O-box, 45
  - included with the instrument, 42
  - optional, 42
- Air trap, 134, 137
  - fill levels, 134
  - fill the air trap, 134
  - fill the optional filter, 137
  - wash tubing, 134
- ÄKTA pilot 600 system, 183
  - specifications, 183
- Ambient environment, 62

## C

- Calibration, 126
  - pH monitor, 126
- CE, 192
  - conformity, 192
  - marking, 192
- Changing, 166
  - pump rinsing solution, 166
- CIP, 161
  - system CIP, 161
- Cleaning, 160, 161, 163
  - flow path, 161
  - instrument surface, 160
  - pH electrode, 163
- Columns, 139
  - instructions for connecting, 139
  - set pressure limits, 139
- Connector panel, 29
- Connectors, 29, 184
  - for ÄKTA pilot 600, 184
- Control panel, 30, 31
  - status indications, 31

## D

- Delivery, 57
  - box, 57
  - box storage, 57

- box transportation, 57
- Documentation, 9, 10
  - on the web, 10
- Documentation package, 8, 9
  - regulatory version, 9
  - standard version, 8

## E

- Emergency, 22
  - procedures, 22
- Environmental conditions, 62
- Extension box, 43
- Extension stand, 44
- External air sensors, 38, 47
  - flow diagram, 47

## F

- FCC compliance, 195
- Filter holder, 41
- Filters, 40
- Flow diagram, 47
  - external air sensors, 47
- Flow path, 122
  - prepare before a run, 122
- Fuse, 177
  - replace, 177

## I

- I/O-box, 45
- Important user information, 6
- In-line filters, 40, 41
  - filter holder, 41
  - steel filter housing, 40
  - ULTA filters, 41
- Inject sample, 147
- Installation, 70, 108
  - computer, 70
  - software, 108
- Instrument, 24–27, 29, 30
  - connectors, 29
  - control panel, 30
  - front panel, 27
  - ON/OFF button, 29
  - rear panel, 29
  - versions, 24–26
- Intended use, 6

Interrupt a method, 151

## L

Log on, 109

UNICORN, 109

## M

Maintenance, 160

clean the instrument, 160

Maintenance program, 156

Maintenance schedule, 156

Manual operations, 146, 151

interact with the run, 151

Manufacturing information, 191

Method, 150

start a method run, 150

Modules, 36

available modules, 36

Monitor the run, 151

## N

Notes and tips, 7

## O

On site service, 200

Operating ranges, 26

Operation, 146, 147, 152, 153

manual, 146

procedures after the run, 152

sample application, 147

shutting down, 153

## P

Perform a run, 151

interact, 151

Periodic maintenance, 156

pH monitor, 163

clean the pH electrode, 163

Power, 29

connector, 29

ON/OFF button, 29

Power requirements, 64

Preparation, 120, 144

before you start, 144

prepare the system for a run,  
120

Prepare the system, 109, 122–124,  
126, 134, 137

air trap, 134

calibrate pH, 126

fill the air trap, 134

fill the optional filter, 137

flow path, 122

pH monitor, 124

replace a filter cassette, 122

replace an ULTA filter, 123

Start UNICORN, 109

Priming, 130, 132

inlet tubing, 130

prime the flow path, 130

system flow path, 132

Process Picture, 52, 54

dialog, 54

Product Documentation, 9

Product return or servicing, 201

Pumps, 166, 168

change pump rinsing solu-  
tion, 166

replace pump rinsing system  
tubing, 168

Purpose of this manual, 5

## R

Rear panel, 29

Reconditioning the pH electrode,  
164

Recycling information, 189

decontamination, 189

disposal of electrical compo-  
nents, 189

recycling of hazardous

substances, 189

Reference information, 183

system specifications, 183

Regulatory information, 190

Regulatory instrument, 25, 26

Replacing, 166, 168, 170, 171

flow path tubing, 170

pump rinsing solution, 166

pump rinsing tubing, 168

valve membranes, 171

Requirements, 64

power, 64

Room requirements, 59

introduction, 59

**S**

- Safety notices, 7
- Safety precautions, 12
  - introduction, 12
- Sample application, 147
- SNAP connectors, 33
- Software, 49, 50
  - overview, 49
  - software modules, 49
  - System Control module, 50
- Software overview, 48
- Space requirements, 59
- Standard instrument, 25, 26
- Start a run, 150
- Steel filter housing, 40
- Storing the pH electrode, 164
- Superloop, 149
- System, 24
  - description, 24
  - overview, 24
- System CIP, 162
- System Control, 50
  - User interface, 50
- System Control module, 51–53
  - color indications, 53
  - icons, 51
  - Process picture, 52
- System sanitization, 162

**T**

- Technical specifications, 183
  - system specifications, 183
- Troubleshooting, 179
- Tube bender, 35
- Tubing, 33, 73, 75, 170
  - attach tubing to a module, 73
  - dimensions, 33
  - disconnect tubing from a module, 75
  - replace tubing, 170
  - SNAP connectors, 33
- Tubing cutter, 34
- Typographical conventions, 5

**U**

- UNICORN, 48, 49, 109, 110
  - connect to system, 110
  - Log on, 109
  - software modules, 49
  - software overview, 49

Start, 109

User documentation, 8

**V**

valve usage statistics, 175

Page intentionally left blank



[cytiva.com/aktapilot](https://cytiva.com/aktapilot)

Cytiva and the Drop logo are trademarks of Global Life Sciences IP Holdco LLC or an affiliate.

ÄKTA, Superloop, ULTA, and UNICORN are trademarks of Global Life Sciences Solutions USA LLC or an affiliate doing business as Cytiva.

Decon is a trademark of Decon Laboratories Ltd. Tween is a trademark of Croda Group of Companies. Microsoft and Windows are registered trademarks of Microsoft Corporation.

All other third-party trademarks are the property of their respective owners.

© 2020 Cytiva

All goods and services are sold subject to the terms and conditions of sale of the supplying company operating within the Cytiva business. A copy of those terms and conditions is available on request. Contact your local Cytiva representative for the most current information.

For local office contact information, visit [cytiva.com/contact](https://cytiva.com/contact)

29261688 AC V:6 09/2020